

UD-154 / UD-084 High-Efficient Switching Power Amplifier with Dante input



UD-154: 1500W x 4 @4Ω/8Ω
UD-084: 750W x 4 @4Ω/8Ω

Contents:

- Overview
- Description
- Getting Started
- Configuration
- Filter & eXtraTone
- Out & In
- Dante
- Applications
- Specifications
- Warranty

UNiKA Electronic Co., Ltd.

www.unika.com.tw

6F, No.168, XinHu 2nd Road,
NeiHu Dist., Taipei 11494,
Taiwan (R.O.C.)

☎ +886-2-27933017

✉ unika@unika.com.tw

The latest version of this manual with color illustration is available for download from our product pages below,
www.unika.com.tw/products-view.php?ID=187 (English)
tw.unika.com.tw/products-view.php?ID=190 (繁體)

09/30/2024

UNiKA UD-154 & UD-084 Switching Power Amplifier

[Overview](#) | [Description](#) | [Getting Started](#) | [Configuration](#) | [Filter & eXtraTone](#) | [Out & In](#) | [Dante](#) | [Applications](#) | [Specifications](#) | [Warranty](#)

Overview:

The UD-154/UD-084 amplifier is a high-efficient switching power amplifier with a concise and intuitive digital control interface. The amplifier is designed to achieve its maximum output regardless of whether an 8Ω or 4Ω speaker on each of its outputs. The internal of the UD-154/UD-084 amplifier is dominantly powered by Pascal Class-D modules with integrated universal power supply with PFC. Thanks to the adoption of the cutting-edge technologies, the amplifier can maintain remarkable quietness in standby or light load conditions.

Each channel of UD-154 amplifier is powered by a completed Pascal module with dedicated power supply of up to 1500W; while each pair of the adjacent channels of the UD-084 amplifier share a power supply to maintain the total output power of the pair of the adjacent channels to 1500W, or 750W per channel evenly. Even more, the amplifier comes with an unprecedented eXtraTone™ mechanism to compensate the speaker for its intrinsic acoustic loss below its bass cutoff. Besides boosting the bass audio on cutoff frequency of the speakers, eXtraTone™ mirrors the audio below the cutoff frequency in a way of harmonic audio over a range of frequency above the cutoff frequency.

Features:

- 1500W x 4 power output regardless of 8Ω or 4Ω speakers on its outputs (UD-154)
- 750W x 4 power output regardless of 8Ω or 4Ω speakers on its outputs, or (UD-084)
1500W x 2 power output if only one of pair of the adjacent outputs is loaded (UD-084)
- High-efficient switching power supply with PFC, and Class-D Switching power amplifier
- Remarkably quiet during standby and light loading
- eXtraTone™ to compensate speaker for loss below its bass cutoff
- 8 digital filters for each channel,
 - 6x filters of 2nd order for generic frequency compensation
 - 2x filters of 4th order for CrossOver implementation
- Each filter can be individually configured as a LoPass, HiPass, Parameter, Notch, Low-Shelf, High-Shelf, or AllPass filter.
- Up to 157ms individual delay control over each output of the amplifier
- Concise and intuitive digital operating interface to cut learning curve
- All-time PPM meter with clip hold indicator for every output channel
- Cooling fans with digital speed controlled
- Voltage and temperature monitoring and protection
- Automatically compresses output in low operating voltage or high operating temperature
- Volume and all the device configuration are automatically saved upon power-off or power loss
- Universal mains power supply operates at AC voltage of full range from 100 to 240V
- Mains with PFC improves efficiency for the distribution system to which it is attached
- Wide range of tolerance in AC voltage
- Sensitivity of inputs of both Analog and Dante (UD-064D) adjustable in a range over 24dB
- Dante network interface in 1Gbps link speed
- Dante audio sample rate up to 96KHz
- Dante Domain Manager (DDM) is supported, and
- Dante Director, a cloud-based management platform, is also supported
- Dante firmware updating from Dante Controller
- Two RJ-45 ports for Dante network make Daisy-chain cascading feasible
- Standard 2U rack-mount metal chassis with innovative premium faceplate

UNiKA UD-154 & UD-084 Switching Power Amplifier

[Overview](#) | [Description](#) | [Getting Started](#) | [Configuration](#) | [Filter & eXtraTone](#) | [Out & In](#) | [Dante](#) | [Applications](#) | [Specifications](#) | [Warranty](#)

Description:

The UD-154/UD-084 is a high-efficient switching power amplifier with a concise and intuitive digital control interface in premium style. Despite its high-power driving capability, the amplifier remains incredibly compact of 2U height and lightweight of just over ten kilograms due to its adoption of power-efficient and advanced switching technologies in both power supply and signal amplification.



1.5KW (UD-154) / 750W (UD-084) power output per channel

The UD-154/UD-084 amplifier is designed to achieve its maximum output regardless of whether an 8Ω or 4Ω speaker on each of its outputs. The UD-154 amplifier has an isolated 1500W DC power supply for each of its outputs to sustain every of its outputs up to 1500W regardless of whether an 8Ω or 4Ω speaker on each of its outputs. Contrastly, each pair of the adjacent outputs of the UD-084 amplifier share a DC power supply to maintain the total output power of each pair of the adjacent channels to 1500W regardless of whether an 8Ω or 4Ω speaker on each of its outputs. Although the UD-084 seems to have merely half the output power of the UD-154 amplifier, each DC power supply of the UD-084 amplifier has the flexibility to deliver 1500W dedicatedly to a single output or 750W x 2 evenly to a pair of adjacent outputs.

eXtraTone™ to Compensate Speaker for Bass Loss

The UD-154/UD-084 amplifier comes with an unprecedented eXtraTone™ mechanism to compensate speaker for its intrinsic bass loss by boosting the bass audio on cutoff frequency of the speakers and mirroring the audio below the the cutoff frequency in a way of harmonic audio over a range of frequency above its cutoff frequency. While doing so the amplifier does not need to waste energy by sending power below the cutoff frequency to speakers, the harmonic mirror of audio below the cutoff frequency enforces the audience perceptible feel of the presence of audio below the cutoff frequency.

Adjustable Delay to Each Output

You have the option to enable a lossless digital delay right in the signal path ahead of the power stage of the UD-154/UD-084 amplifier. There are actually 4 delays for the 4 channel outputs and the delay time of each delay is independently adjustable up to 157ms in step of mini-second. The 157ms of delay time is equal to 54m (or 177ft) in speaker displacement which should be far enough for a small to medium performance venue.

Extended Sensitivity Control for Analog and Dante Inputs Respectively

Sensitivity control can be independently configured for analog and Dante inputs in the UD-154/UD-084 amplifier. Even more, the control range of both sensitivity are extended to 24dBu which means the analog sensitivity can be adjustable from 0dBu up to 24dBu while the Dante sensitivity can be adjustable from

UNiKA UD-154 & UD-084 Switching Power Amplifier

[Overview](#) | [Description](#) | [Getting Started](#) | [Configuration](#) | [Filter & eXtraTone](#) | [Out & In](#) | [Dante](#) | [Applications](#) | [Specifications](#) | [Warranty](#)

-24dB up to 0dB. The extended range of sensitivity control allows the amplifier to easily align with the other similar devices with a variety of sensitivities.

Concise and Intuitive Digital Control Interface

All the features and functionalities of UD-154/UD-084 amplifier are precisely controlled digitally to avoid over time annoying degradation or deviation introduced by traditional analog treatment. For simplified operation, there are mere two buttons and one encoder for the whole control and monitoring operation. While the control interface is concise, the information from it is far rich. Besides the digital volume control and 32-segment PPM meter with clip hold for each output channel, the digital processor thoroughly provides device information including temperature of each heatsink and transformer, revolution speed of each fan, AC voltage, input parallelized, and etc.. Of course, all the device configuration, such as input parallelization, input selecting, input sensitivity selecting, and etc., are set in a digital way to minimize the chance of hardware failure.

Maintaining Performance According to Operating Voltage and Temperature

The audio outputs of UD-154/UD-084 amplifier are constantly monitored by a digital processor and the processor automatically compresses the audio to avoid audio clip due to low operating voltage or to avoid overheat failure due to high operating temperature.

Low operating internal voltage can be caused by insufficient AC voltage on the field or heavy load on the amplifier outputs. The digital processor compresses the peak portion of audio in a timely manner to avoid clip sound due to the possible output being capped by the low operating voltage. This dramatically improves the audio perceptibility by the audience whereas only a little of loudness on peak volume is sacrificed.

Operating temperature in the amplifier is always a big impact to the performance of the amplifier. The processor in the UD-154/UD-084 amplifier tightly controls the revolution speed of the fans in the chassis to cool down the temperature in every heatsink and power transformer. In extreme case, if the fans with their max revolution speed still can't blow out the heat fast enough, the built-in audio compressor in the amplifier will compress the peak volume of audio to cut down the power dissipation to avoid device failure due to overheat.

Universal Mains Power Supply

The UD-154/UD-084 amplifier comes with Universal Mains Power Supply which means the amplifier can work straightaway in any environment of AC ranging from 90 ~ 240V without the user having to do any setting of AC select in advance.

PFC improves efficiency for the power distributing and also delivers constant maximum power at all AC voltages

Beside the capability to operate in the universal AC range mentioned above, the UD-154/UD-084 amplifier also has built-in PFC (Power Factor Correction) which improves efficiency for the power distribution system to which the amplifier is attached. Furthermore, incorporating the internal regulator, the amplifier can deliver constant maximum power across the entire range of AC voltages. That is to say, the maximum output power of the amplifier when it is powered by 110V AC source is quite close to the one when it is powered by 240 AC source.

Auto-Save on Power Loss

After power up, the processor in the UD-154/UD-084 amplifier automatically brings up all the previous settings used in previous run time. The processor can even gradually turn up the output volume from mute to their previous so that, on every power recycle, the user doesn't need to set the volume again while avoiding pop noise on power rush simultaneously. The processor can even capture the settings, including volume settings, on the failure caused by an AC shortage.

UNiKA UD-154 & UD-084 Switching Power Amplifier

[Overview](#) | [Description](#) | [Getting Started](#) | [Configuration](#) | [Filter & eXtraTone](#) | [Out & In](#) | [Dante](#) | [Applications](#) | [Specifications](#) | [Warranty](#)

Dante Digital Audio Input

The UD-154/UD-084 amplifier is also equipped with a x4 channels Dante interface which allows the amplifier to work fully digitally by receiving digital audio from the popular Dante network. We fully integrate the Dante capability to our UD-154/UD-084 amplifier so that users can also quickly browse all the Dante information, such as Dante Name, Sample Rate, Sync status, IP address, device lock status, DDM enrollment, and etc., on the display of the front panel. The UD-154/UD-084 amplifier can even display the events received from the Dante Network, including events for device identify, clear configuration, reboot, firmware upgrading, and etc.

UNiKA UD-154 & UD-084 Switching Power Amplifier

Getting Started Guide:

Installation

Although the internal processor of UD-154/UD-084 amplifier can optimize the performance of the amplifier according to the operating environment, too much high operation temperature and intermittent AC source void the guarantee of the performance of the amplifier to meet the specifications.

Powering

The UD-154/UD-084 amplifier can work in a universal range of AC voltage from 100 to 240V. User does not need to set any selection about AC voltage range before plugging the amplifier to an AC outlet. A diffused white LED is integrated into the power switch to indicate its ON/OFF status. The LED flashes when the CPU in the amplifier is checking and setting the amplifier for ready use. The LED is solid light when the amplifier is ready for usage.



The UD-154/UD-084 amplifier receives AC power via a 12AWG/10AWG power cord for rugged and safe power connection. A push-to-reset circuit breaker is located above the insertion of the power core on the back plate for additional overload protection.

The UD-154 amplifier is not shipped with a power plug on its power cord. Here is a wiring guide for the possible color code of power cords to the power distribution system in the installation site.

	Hot/Line	Neutral	Ground/PE
Europe	Brown	Blue	Green-Yellow
US	Black	White	Green
ANZ/IN	Red	Black	Green



The input of mains in the internal of the UD-154/UD-084 amplifier is transformer isolated which means the Hot/Line and Neutral are interchangeable in wiring and are not strictly defined.

Control & Monitoring Interface

Besides the prominent LCD display on the center of the front panel, there are only two buttons (BACK & INFO/SET) and one ENCODER for users to navigate all the control settings and monitoring status. The concise and intuitive user interface leads to dramatically cutting down the users' learning curve, so that most people probably don't need to read through the whole manual to setup the amplifier for operation.

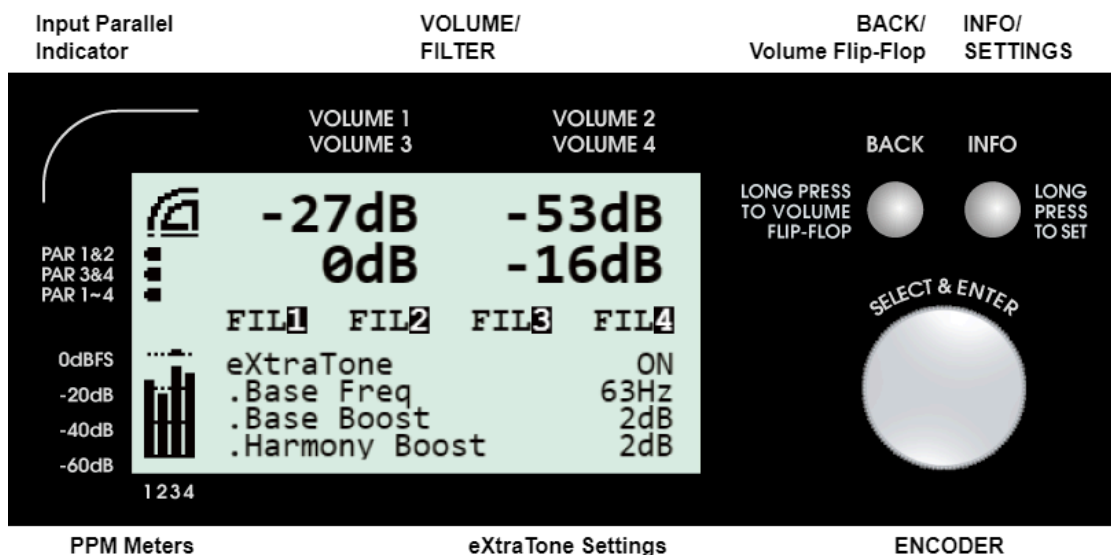

UNIKA UD-154 & UD-084 Switching Power Amplifier

ENCODER There are two operation modes for the ENCODER,

1. browse mode: to browse the content for read only.
2. edit mode: to edit the value of the item being browsed to.

Briefly pressing the ENCODER can switch back and forth between the browse mode and edit mode.

Usually, the ENCODER is in browse mode for users to browse the operating status or device information. If the item being browsed to is editable, the selected item is enclosed by a box or highlighted by text reversing. Simply pressing the ENCODER will have the ENCODER switch to edit mode. When the ENCODER is in edit mode, a flashing edit bar scores under the selected item or blinking highlighted text appears to remind the user that the item is now editable by rotating the ENCODER again. Rotate the ENCODER to change or edit the value of the selected item to whatever you want, and briefly press the ENCODER again to complete the editing and exit edit mode. Pressing the BACK button when the ENCODER is in edit mode can also bring back the ENCODER to browse mode.

For example, as illustrated on the right, the amplifier always starts up with the VOLUME menu in the middle of the display. When you 1st rotate the ENCODER in the the VOLUME menu, you browse to the channel you wish to do the volume tuning. The channel to which you are browsing is indicated by a boxed enclosure. Once you press the ENCODER, the channel to which you are browsing is editable and an underscored edit bar is flashing to indicate the selected item in edit mode. You then can now edit the volume by rotating the ENCODER again. Once you complete your volume tuning, press the ENCODER again (or press BACK button alternatively) to exit edit mode. The edit bar below the selected item vanishes to indicate backing to browse mode.

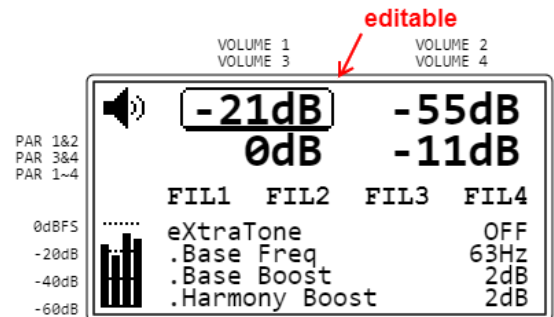

TIP:

- The above operations can be completed in a very swift way. Simply press and hold the ENCODER on the selected item and simultaneously rotate the ENCODER to change the value of the selected item. Release the ENCODER once you O.K. the new change. The ENCODER and the selected item will automatically exit edit mode after you release the ENCODER.
- The increment and decrement step is variable depending on the speed you rotate the encoder. So that you can turn volume up to its maximum or down to its minimum in one shot by rotating the encoder very quickly.

BACK The BACK button, as implied by the name, backs to the previous menu or exits the edit mode or browse mode. You can always simply press the BACK button a couple of times to go back to the startup VOLUME menu once you are lost in the menu navigation. Briefly press the BACK button when ENCODER in EDIT mode makes ENCODER leave the edit mode; While briefly press the BACK button when ENCODER in browse mode make the ENCODER leave the browse mode and save the edited value previously modified in edit mode.



TIP:

There is a hidden feature in the BACK button. By long pressing the BACK button for more than one second, you trigger the controller to volume down or up all the channels of the amplifier to MUTE or their maximum depending on the current volumes. If there is a volume of any channel not muted, you long press the BACK button will volume down all channels to mute. If all the volumes of the channels are muted, you long press the BACK button will bring up the volumes of all channels to their maximum.

INFO/SET There are two functions in the INFO/SET button.

UNiKA UD-154 & UD-084 Switching Power Amplifier

Overview	Description	Getting Started	Configuration	Filter & eXtraTone	Out & In	Dante	Applications	Specifications	Warranty
----------	-------------	-----------------	---------------	--------------------	----------	-------	--------------	----------------	----------

1. Info: Briefly press the button to cycle through the different read-only menu for operating status or device information.
2. Set: Long press the button to the editable SETTINGS menu to set the device configuration.

The INFO/SET button is for displaying device information or setting the device configuration. Briefly press the INFO/SET button cycles through the status and information categorized as device info (INFO), Dante (DANTE), temperature (TEMP), and fan speed (FAN). Each category may contain many items of status/information which can be browsed by rotating the ENCODER. You can also use the ENCODER to browse across the category boundary back and forth for quick navigation. Browsing to the end of items or pressing the BACK button will intermediately return back to the startup VOLUME menu.

Long pressing the INFO/SET button for more than one second will bring up the device SETTINGS menu. You can then browse the settings items by rotating the ENCODER, edit the selected item by pressing the ENCODER, and complete the setting by pressing ENCODER again or by pressing BACK button.



TIP: Similarly to volume editing, you can also swiftly edit the selected setting item by pressing and holding ENCODER and simultaneously rotating the ENCODER until you feel O.K. to complete the setting by releasing the ENCODER.

LCD Display The LCD display in the middle of the front panel shows the amplifier operating status and device information. The initial menu shown up after power startup is the VOLUME menu. You can cycle through to other menus by briefly pressing the INFO/SET button or go to the SETTINGS menu by long pressing the INFO/SET button.

Four PPM meters and three parallelized indicators are permanently shown up on the left of the display, no matter what menu is cycled through in the middle on the display. The PPM meters show the output audio level for each channel of the amplifier. The 0dBFS is aligned to the amplifier maximum output which means you should never drive the input level, combined with the volume control and eXtraTone™ bass boost, over the threshold of 0dBFS. Otherwise, you hear an audible clip noise on the output of the amplifier. There are clip hold indicators on the top of each PPM meter to bring up your attention if the amplifier is overdriven. The 32 segments of each PPM is scaled from 0dBFS down to -60dB with each little segment representing a 2dB difference in signal strength.

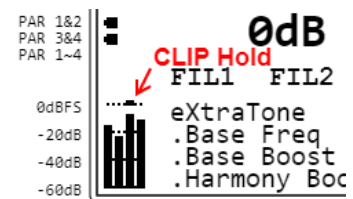

NOTE:

- The analog input sensitivity to drive the amplifier to its 0dBFS maximum output is configurable in the SETTINGS menu. You can cycle through 0dBu, 1V, and 1.4V for sensitivity setting while the factory default is set to 1.4V.
- The output of the amplifier can also be clipped when the railed DC voltage from the power supply is insufficient due to lower AC voltage or heavy loading on output of the amplifier. When it happens at first time, the backlight of the display also flashes to bring up your attention.

Operation Menu on Display

There are totally 7 operation menus: VOLUME, INFO, DANTE, TEMP, FAN, FILTER, and SETTINGS.

The UD-154/UD-084 amplifier starts up by default by showing the VOLUME menu in the middle of the display.

- Briefly pressing the INFO/SET button will cycle through to the additional operation menus, in the order of INFO, DANTE, TEMP, FAN, and back to VOLUME.
- Briefly pressing the ENCODER button when a FIL (FIL1, FIL2, FIL3, FIL4) is browsed to, this opens the corresponding FILTER menu for the particular channel.
- Long pressing the INFO/SET button will specially bring up the SETTINGS menu for device configuration.

UNiKA UD-154 & UD-084 Switching Power Amplifier

The details of these menus are described below,

- VOLUME menu:** A speaker icon is stayed on the upper left of the display when the content of the VOLUME menu is being browsed. The VOLUME menu is where you can tune the channel volume individually. Rotate the encoder to browse to different channels you wish to tune its volume, and press the ENCODER for tuning the volume of the selected channel.

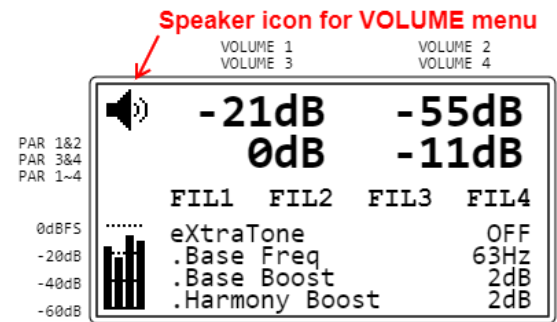

The VOLUME menu is the default menu when the amplifier starts up. You can always press the BACK button a couple of times to return back to the VOLUME menu when you are lost in menu navigation.



NOTE:

- The speaker icon on the upper left of the display will be replaced with a Dante icon if you configure the amplifier to source input from the Dante audio network. Dante audio input will be described later in the manual.
- When you forward browse and roll over the last channel in the VOLUME menu, you are browsing to the FILTER and eXtraTone™ setting items which will be particularly described later in the manual.
- If you enable the delay in the SETTINGS menu and backward browse and roll over the 1st channel in the VOLUME menu, you are browsing to the DELAY menu where you can trim time delay of every output individually. The speaker icon on the upper left will be replaced with a time clock when you browse to the DELAY menu.
- As mentioned previously, you can mute all the channels by long pressing the BACK button for more than one second. If all of the channels are already muted, you, on the contrary, volume up all channels to their maximum by long pressing the BACK button.

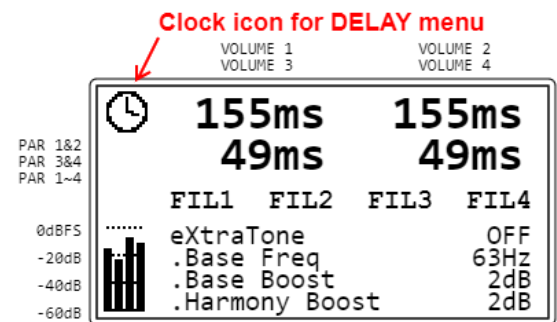

- INFO menu:** An information icon is stayed on the upper left of the display when the content of INFO menu is being browsed. The INFO menu is where you can browse through the device operating information of the amplifier, including,
 - Model: Model Number of the device
 - UID: Unique ID assigned to the device
 - SW: Firmware Version in the device
 - Compressing: Compressing level on Output
 - ACin@PowerON: AC Voltage at the moment of powering on

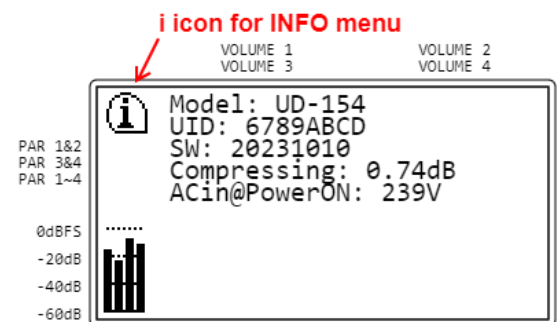

NOTE:

- A built-in compressor for output is automatically engaged due to high operating temperature or low operating voltage.
- Long time operating the device in high temperature can cause the device to cease operation due to part failure. The compressor will dynamically compress the audio in the portion of high level when the temperature of any of the monitoring spots in the amplifier is over about 55°C in order to reduce the power dissipation and cut heat generation.
- Low AC voltage can cause audible clips due to insufficiency of rectified and filtered voltage to drive the output to its nominal maximum. The compressor also compresses the

UNiKA UD-154 & UD-084 Switching Power Amplifier

output audio in the portion of high level to avoid the audible clip noise when a low operating voltage is detected.

- The Compressing item shows how many dB of output level is compressed due to high operating temperature or low operating voltage.
- The operating temperature in many of the monitoring spots in the amplifier can be found on the TEMP menu described later.
- The estimated AC voltage at the instant of powering on from the AC outlet is shown on the item next to Compressing. The AC voltage reading is just for quick reference and is not supposed to replace the meter that you use to measure AC voltage on a daily basis.

- **DANTE menu:** UD-154/UD-084 amplifier comes with a Dante interface built-in. A Dante icon is stayed on the upper left of the display when the content of the DANTE menu is being browsed. The DANTE menu is where you can browse through the Dante related information in the amplifier, including,

- Dante Name
- Dante Sample Rate
- Dante Clock Sync Status
- Ethernet Link Speed
- IP address assigned to the device
- Whether the device is locked by Dante Controller
- The DDM manager to which the device is enrolled
- Whether the device is connected to a Dante Domain

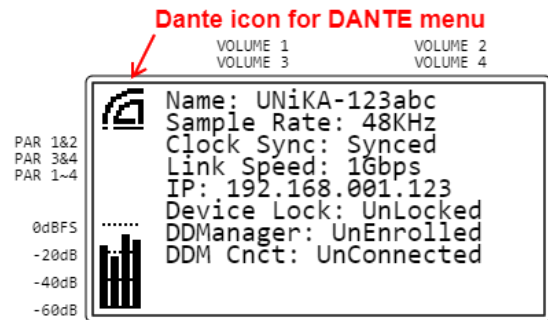

NOTE:

- All the Dante related settings are configured by Dante Controller software. And the Dante interface of the UD-154/UD-084 amplifier can be locked with password protect via the Dante Controller software.
- The Dante interface of the UD-154/UD-084 amplifier can also be enrolled in a DDM domain and be managed. In this circumstance, the configuration of the Dante interface can't not be changed without the allowance or the password of the DDM manager.
- Also, you should make sure that the setting of the Dante sample rate of your UD-154/UD-084 amplifier to align with the sample rate of your whole Dante network. Basically, **all the devices in the same Dante network should be synced to the same sample rate.**

- **TEMP menu:** A thermometer icon is stayed on the upper left of the display when the content of TEMP menu is being browsed. The TEMP menu is where you can find the operating temperature of all the monitored spots in the amplifier, including

- Temperature of Heatsink and power transformer for channel 1
- Temperature of Heatsink and power transformer for channel 2
- Temperature of Heatsink and power transformer for channel 3
- Temperature of Heatsink and power transformer for channel 4
- Temperature of Digital Processor

The unit of temperature can be changed between °C and °F from TEMP setting item in the SETTINGS menu.

- **FAN menu:** A fan icon is stayed on the upper left of the display when the content of the FAN menu is being browsed. The FAN menu is where you can read the revolution speed of cooling fans in the amplifier, including

- Speed of Fan for amplifier of CH1

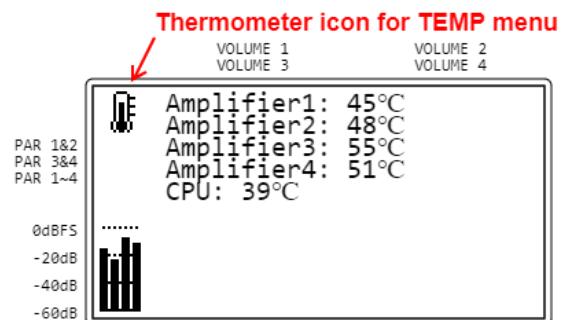

UNiKA UD-154 & UD-084 Switching Power Amplifier

- Speed of Fan for amplifier of CH2
- Speed of Fan for amplifier of CH3
- Speed of Fan for amplifier of CH4

The unit of fan speed can be changed between RPM (Revolutions per Minute) and RPS (Revolutions per Second) from the FAN setting item in the SETTINGS menu.

- **FILTER menu:** A spectrum icon is stayed on the upper left of the display when the content of a FILTER menu is being browsed. The FILTER menu is where you can configure the filter parameters to the amplifier. The details of the parameters for each different type of filter are described later in the section for Filter & eXtraTone™.
- **SETTINGS menu:** A gear icon is stayed on the upper left of the display when the content of the SETTINGS menu is being browsed. The SETTINGS menu is where you can configure the operating parameters to the amplifier. The details of each setting item are described in the following section for device configuration.

Fan icon for FAN menu

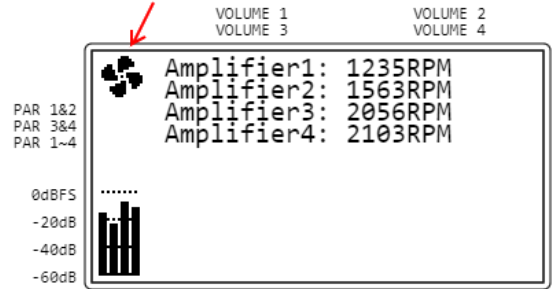

Spectrum icon for FILTER menu

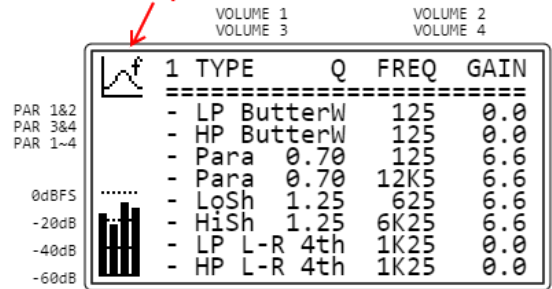

Gear icon for SETTINGS menu

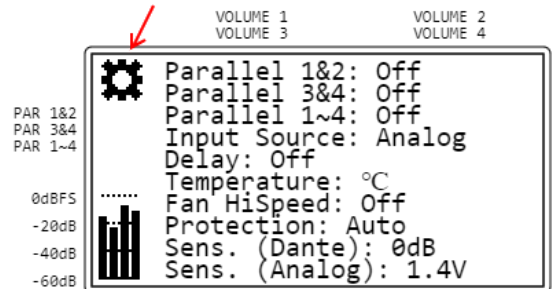

UNiKA UD-154 & UD-084 Switching Power Amplifier

Device Configuration:

Long pressing the INFO/SET button more than one second will bring up the SETTINGS menu. You can browse the content of the SETTINGS menu by rotating the ENCODER. Once you find the item you wish to change the value of it, switch the ENCODER to edit mode by pressing the ENCODER on the selected item. You will see the selected item is highlighted and flashes. This reminds you that the selected item is now editable. You can then rotate the ENCODER again to change the value of the selected item to whatever you need. Once you feel O.K. for the change to the item, simply press the ENCODER again or press the BACK button to leave the edit mode.



TIP: The above operations can be completed in a very swift way. Simply press and hold the ENCODER on the selected item and simultaneously rotate the ENCODER to change the value of the selected item. Release the ENCODER once you O.K. the new change. The ENCODER and the selected item will automatically exit edit mode after you release the ENCODER.

Here is the list of items in the SETTINGS menu,

- **Parallel 1&2:** Input1 and Input2 are parallelized and fed with the signal from input1 (InputL), input2 (InputR), or a half and half mix of them (MixL+R). The outputs of both channels are still able to be controlled by their Volume controls respectively.
- **Parallel 3&4:** Input3 and Input4 are parallelized and fed with the signal from input3 (InputL), input4 (InputR), or a half and half mix of them (MixL+R). The outputs of both channels are still able to be controlled by their Volume controls respectively.
- **Parallel 1~4:** Input1, Input2, Input3, and Input4 are all parallelized, and all channels are fed by Input1. Input2, Input3, and Input4 are all disconnected internally to avoid unconscious noise coupling.

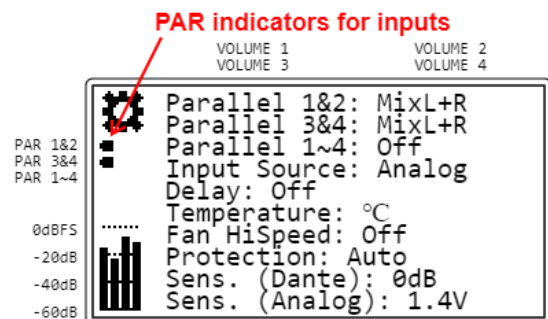

NOTE:

- Three small Parallel indicators on the left of the display show up to remind users how inputs are parallelized.
- Turning on **Parallel 1~4** will forcibly disable **Parallel 1&2** and **Parallel 3&4** automatically.
- There are three options for the input of **Parallel 1&2** or **Parallel 3&4**,
 - InputL: both channels are driven by the left signal which would be Input1 in case of **Parallel 1&2** or Input3 in case of **Parallel 3&4**.
 - InputR: both channels are driven by the right signal which would be Input2 in case of **Parallel 1&2** or Input4 in case of **Parallel 3&4**.
 - MixL+R: both channels are driven by a half and half mix of left and right signals.
- **Input Source:** UD-154/UD-084 amplifier comes with a Dante interface installed. This is where you can switch to receive audio from the Dante network.
 - Analog: default analog audio inputs from XLR sockets are selected.
 - Dante: Dante network audio from RJ-45 ports is selected as input.Please be informed that changing the source of input will reset all the volume to MUTE to prevent unconsciously overloading the amplifier due to overdriven input signal.
- **Delay:** To enable the delay in the signal path ahead of the power stage of the amplifier, set it to any of the following values other than Off,
 - ms: delay will be displayed in milli-second as unit.
 - meter: delay will be displayed in meter as unit.
 - foot: delay will be displayed in foot as unit.
 - Off: delay is OFF from the signal path.

UNiKA UD-154 & UD-084 Switching Power Amplifier

The delay time can be adjusted from the DELAY menu which can be shown by backward browsing over the 1st channel in the VOLUME menu. Switching the delay to OFF will hide the DELAY menu from operation.

- **Temperature:** This is where you can switch between °C and °F as unit of temperature displayed in the TEMP menu.
- **Fan Revolution:** This is where you can switch between RPM (Revolutions per Minute) and RPS (Revolutions per Second) as unit of fan speed displayed in the FAN menu. For the sake of simplification, the setting can be permanently set to RPM and hidden from users.
- **Fan HiSpeed:** This makes the fan run at a higher speed to aggressively cool down the amplifier if the internal operating temperature of the amplifier suddenly raises.. By default the setting item is disabled to make the amplifier operate quietly. The default setting should be good for most circumstance unless you plan to put the amplifier to work in an environment with temperature of more than 40°C (or 104°F).
- **Protection:** A built-in compressor will by default automatically compress the output in low operating voltage or high temperature. You have the option to disable the compressor for whatever reason, though doing so can more likely lead to audible clip noise due to low operating voltage or amplifier shutdown due to over temperature.



NOTE: In some markets, the compressor may be forcibly set to engage automatically to prevent the amplifier from inadvertently running into shutdown or causing any permanent damage in the amplifier.

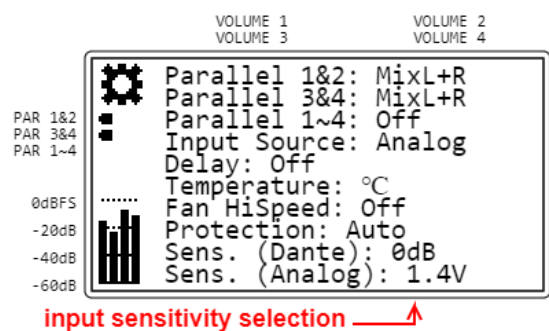

- **Sensitivity:** This is where you can set the input sensitivity to drive the amplifier to its 0dBFS maximum.
 - **Analog:** You can cycle through 0.775V (0dBu), 1V, and 1.4V for analog sensitivity while factory default is set to 1.4V. The amplifier also has extended sensitivity selection which allows you even set the sensitivity up to 24dBu in step of 6dB.
 - **Dante:** Dante sensitivity is still widely selectable from -24dB ~ 0dB in step of 6dB. Factory default is set to 0dB so that is maximum of Dante input is aligned with the maximum output of the amplifier.

UNiKA UD-154 & UD-084 Switching Power Amplifier

Auto-Save and Reset Device Settings/Configuration

Auto-Save: All the items of settings or configuration, including the items for volume and eXtraTone™, you change in edit mode are saved automatically when you press the BACK button to leave the browse mode. When the processor is saving one or more items in the background, the background light of the display flashes once to bring your attention to the saving activity. You don't need to press the BACK button every time you edit an item because the processor will auto-save everything unsaved every time you press the POWER button to switch off the amplifier. An unexpected interruption of AC power will also trigger an auto-save activity so that you won't lose any modified setting or configuration.

Reset: For whatever reason, you may want to reset the settings of your UD-154/UD-084 amplifier back to its factory default. To do so, press and hold the BACK button when you press the POWER button to start up the amplifier. Once you see a message of "Device Reset to Default" with a wrench icon on the upper left of the display, the amplifier has reset to its factory default. You can then release the BACK button and the amplifier is ready for further operation.

Please be informed that the above reset operation does not affect the configuration of the Dante interface in the UD-154/UD-084. To bring the configuration of the Dante interface to its factory default, you must either,

- have your device connect to a computer running Dante Controller software and trigger a reset by pressing the "Clear Config" button on the tab of device config in the device view window for your UD-154/UD-084. You need to re-power your UD-154/UD-084 for the default settings to take effect after you see a message about "Dante Reset to Default" on the display of your UD-154/UD-084. Please be informed that you can't reset Dante configuration via Dante Controller if the Dante interface is previously locked. You must click the "unlock" button on the UD-154/UD-084 device view window of the Dante Controller to unlock the Dante interface before you can reset its configuration.
- press and hold the DEFAULT button next to RJ-45 ports on the rear panel of your UD-154/UD-084 when you press the POWER button to start up your UD-154/UD-084. After more than 5 seconds you press the POWER button, you can release the DEFAULT button and re-power your UD-154/UD-084 for the default settings to take effect.

Furthermore, if the Dante interface of your UD-154/UD-084 is previously enrolled in a DDM managed domain, all the setting operations, including resetting to factory default, can only be achieved via Dante Controller with DDM password. If you forgot to un-enroll the Dante interface of your UD-154/UD-084 before it disconnected from the managed environment, the Dante interface of your UD-154/UD-084 is not going to work in any other managed or unmanaged environment anymore. To reset the Dante interface of your UD-154/UD-084 from the previous managed enrollment, you need to clear the domain credentials in the Dante interface of your UD-154/UD-084. Solely (i.e., no other Dante device involved) connect the Dante interface of your UD-154/UD-084 to your computer with Dante Controller running, and click the "clear Domain credentials" under the device drop down menu on device view window to your UD-154/UD-084.

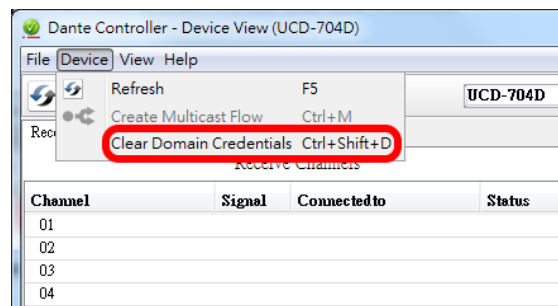

UNIKA UD-154 & UD-084 Switching Power Amplifier

Error & Service Message

Although it is scarcely, you may see some kind of messages with a wrench icon on the upper left of the display. This is something about the operating event which need to be brought up to your attention, such as follows,

- **Over Temp:** It means the amplifier is now working at over temperature. This message comes out with a number showing the current operating temperature. A message of Over Temp may immediately trigger a shutdown of DC power supply to the amplifier which will consequently mute the audio on the outputs of the amplifier. When it happens, the amplifier is not able to go back to work again and a message about "requiring a re-power on" will also pop up on the display. Once you re-power the amplifier, you may also have to wait for the amplifier to cool down below 80°C to let the amplifier get ready to work again.
- **AC Shortage:** It means an AC shortage is detected. This message comes out with a number showing the current AC voltage. When it happens, all the four internal output amplifiers will be disabled so that all the outputs are muted. Of course, the processor in the device may enable the internal amplifiers to go back to work after the AC source steadily comes back. Please be informed, although the output is immediately muted when AC Shortage is detected, the volume meter remains the last state before mute.
- **Check AC Volt:** It means an abnormal AC voltage is detected. This message comes out with a number showing the current AC Voltage. For example, if an AC voltage far above 127V but far below 220 is detected, the error message will pop up to bring it to your attention.
- **Checking ACV:** It means the processor is checking the range of AC voltage. This message comes out with a number showing the current AC Voltage. The message usually comes out briefly at the very beginning when you press the POWER switch for the processor to determine how to switch the rectifier circuit to meet the voltage fed from the AC socket.
- **AC Over Volt.:** It means an AC over voltage is detected. This message comes out with a number showing the current AC Voltage. Although it won't have an immediate impact on the amplifier operation, keeping the amplifier running at an excessively high AC voltage will shorten the life of the amplifier.
- **Overloaded:** It means one or more of outputs is overloaded, which can further cause even severe output failure such as a DC voltage appearing on outputs. All the four internal output amplifiers are immediately disabled to prevent further possible damage on the speakers connected. Since it belongs to a fatal event, the power supply in the device will be also forcibly died out and won't startup again without a re-powering. If the message appears again after the amplifier is re-powered on, you may have to contact the factory for repair service. Please be informed that a huge clipped audio may also cause "Overloaded" due to the fact that the clipped portion of audio is actually DC. Therefore, please don't overdrive the amplifier to make any of its outputs clipped. Moreover, although the output is immediately muted, the volume meter remains the last state before mute, which lets the audio technician know the volume when overload occurs.
- **Fan Stuck:** It means any one of the fans in the amplifier gets stuck for whatever reason. This message comes out with a number showing the fan speed of the affected fan. The error won't have a direct impact on the operation of the amplifier initially, but can lead to a failure caused by over temperature in the long term.
- **Device Reset to Default:** It reminds you that you have reset the amplifier to its factory default. As it was mentioned previously, users can reset the amplifier to its factory default by pressing and holding the BACK button while powering on the amplifier.

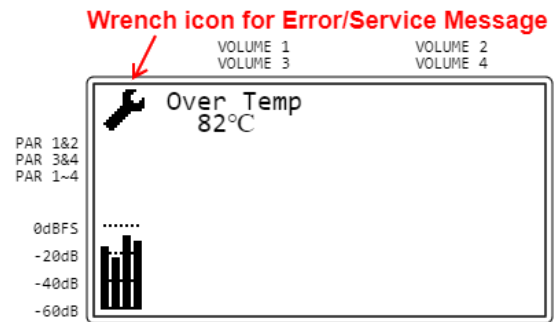

UNiKA UD-154 & UD-084 Switching Power Amplifier

Overview | Description | Getting Started | **Configuration** | Filter & eXtraTone | Out & In | Dante | Applications | Specifications | Warranty

- **Dante Reset to Default:** It means that someone has reset the Dante interface of the amplifier to its factory default from Dante Controller software. The reset won't affect the current session of operation. You need to re-powered the amplifier for the default settings to take effect on next run time.
- **Dante is Rebooting:** It means that someone has triggered a reboot to the Dante interface of the amplifier from Dante Controller software.
- **Dante was Rebooted:** It means that the Dante interface has completed its reboot process. You may sometimes need to re-power the amplifier for the processor in the amplifier to regain control of the Dante interface.
- **Dante in Upgrading:** Dante interface is in a process of software upgrading. Please wait for the upgrade to complete and then re-power the amplifier.
- **Upgrade Done:** The Dante interface of the amplifier has just completed a process of firmware upgrade. Please re-power the amplifier.
- **Dante not OK:** It means that Dante interface is not ready for operation. This can happen if you re-powered on the amplifier immediately right after it was powered off. You may have to turn off the amplifier again and wait for a couple of seconds to re-power it to let the Dante interface get a complete recycle restart.

Most of the time, you can simply press the BACK button to ignore the error/service message even if the power supply of the amplifier has been shut down for protection. However, a similar error/service message may pop up again if an even worse condition occurs. For example, a message of a fan stuck at 1.2KRPM may pop up after you ignored a message of a fan stuck at 1.5KRPM.

UNiKA UD-154 & UD-084 Switching Power Amplifier

Filters to Compensate the Acoustic Loss

The UD-154/UD-084 amplifier comes with 4 sets of filters, each dedicated to a channel. Each set of filters can be a composite of up to 8 subfilters in cascade.

The settings of each set of filters can be edited by browsing to and entering on FLT1 ~ FLT4 with ENCODER on VOLUME menu. The tagged numbers of FLT1 ~ FLT4 will be highlighted if the corresponding filters are engaged in the signal path, as illustrated on the right.

Every subfilter can be independently configured for a different filter type or filter algorithm. All the supported filter types/algorithms are listed below,

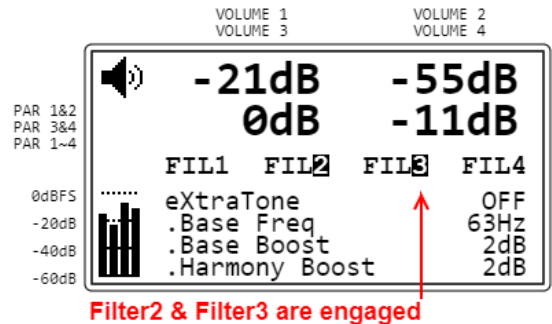

Name	Filter Type/Algorithm	Order	Parameters (Adjustable)	Parameters (Fixed)
LP 1st	LowPass	1st	Cut-off Frequency	Gain=0dB
LP ButterW	LowPass ButterWorth	2nd	Cut-off Frequency	Gain=0dB, Q=0.707
LP Bessel	LowPass Bessel	2nd	Cut-off Frequency	Gain=0dB, Q=0.577
LP ChebySh	LowPass ChebyShev	2nd	Cut-off Frequency	Gain=0dB, Ripple=0.1dB
HP 1st	HighPass	1st	Cut-off Frequency	Gain=0dB
HP ButterW	HighPass ButterWorth	2nd	Cut-off Frequency	Gain=0dB, Q=0.707
HP Bessel	HighPass Bessel	2nd	Cut-off Frequency	Gain=0dB, Q=0.577
HP ChebySh	HighPass ChebyShev	2nd	Cut-off Frequency	Gain=0dB, Ripple=0.1dB
AllP 1st	AllPass	1st	Center Frequency	Gain=0dB
AllP	AllPass	2nd	Q, Center Frequency	Gain=0dB
LP	Generic LowPass	2nd	Q, Cut-off Frequency	Gain=0dB
HP	Generic HighPass	2nd	Q, Cut-off Frequency	Gain=0dB
BPss	Band Pass	1st	Bandwidth in Octave, Center Freq	Gain=0dB
BStp	Band Stop	1st	Bandwidth in Octave, Center Freq	Gain=0dB
LoSh	Low Shelf	2nd	Slop, Shelving Freq., Gain	
HiSh	High Shelf	2nd	Slop, Shelving Freq., Gain	
Para	Parameter	2nd	Q, Center Frequency, Gain	
Ntch	Notch	2nd	Q, Center Frequency	Gain= -∞
LP L-R 4th	LowPass Linkwitz-Riley	4th	Cut-off Frequency	Gain=0dB
LP BW 4th	LowPass ButterWorth	4th	Cut-off Frequency	Gain=0dB
LP Bsl 4th	LowPass Bessel	4th	Cut-off Frequency	Gain=0dB
HP L-R 4th	HighPass Linkwitz-Riley	4th	Cut-off Frequency	Gain=0dB
HP BW 4th	HighPass ButterWorth	4th	Cut-off Frequency	Gain=0dB
HP Bsl 4th	HighPass Bessel	4th	Cut-off Frequency	Gain=0dB

A subfilter is enabled by browsing to the "-", ahead of the filter name, and changing it to "+", which means the subfilter is added to the signal path. In contrast, to remove a subfilter from the signal path, simply browse to the leading "+" for the subfilter and change it to "-".

Once one or more subfilters are added to the signal path, the number (#) on the corresponding FIL# symbol below the VOLUME menu is highlighted to indicate the involvement of the channel filter.



TIP:

The last two, and only the last two, subfilters are 4th order filters which are specially designed for CrossOver implementation. The Linkwitz-Riley filter in the category is particularly ideal for CrossOver implementation. The filter has a 180° phase deviation at the cut-off frequency, which perfectly makes up the total phase deviation at the CrossOver frequency to virtually zero when such a CrossOver is composed of a LowPass Linkwitz-Riley and a HighPass Linkwitz-Riley with their cut-off frequency set exactly the same.

UNiKA UD-154 & UD-084 Switching Power Amplifier

eXtraTone™ to Boost the Bass Performance of Speakers

eXtraTone™ is an unprecedented digital algorithm to boost and compensate the speaker for loss below its bass cutoff.

Most speakers have their -6dB or -10dB bass cutoff frequency around 70Hz or so. Audio technicians may try to extend acoustic response below the cutoff frequency by sending more power below the cutoff frequency to speakers. However, sending more power below the cutoff frequency to speakers actually just wastes energy over the speakers but does no benefit on audible bass perception to the audience.



eXtraTone™, on the contrary, cuts down the power of audio below the cutoff frequency to the speakers. Besides boosting the audio on the cutoff frequency of the speakers, the eXtraTone™ mirrors the audio below the cutoff frequency up to the range of frequency above the cutoff frequency in a way of harmony. Though the audio below the cutoff frequency is cutting down, the audience can actually perceive the presence of bass through the harmonic audio over a range of frequency above the cutoff frequency.

Users browse to eXtraTone™ setting items by rotating the ENCODER over the last item of channels in the VOLUME menu. The setting items include,

- eXtraTone™ On/Off: You have the option to turn off the eXtraTone™ feature.
- Base Frequency: We recommend you to set this to the -6dB or -10dB cutoff frequency of your speakers. The eXtraTone™ provides a significant bass boost over the audio on the base frequency. Default is 63Hz.
- Base Boost: Here you can set the intensity of bass boost on the base frequency set above. The eXtraTone™ can boost a great amount of bass over the base frequency. Default is +2dB.
- Harmony Boost: Here you can set the intensity of the harmonic mirror of audio below the base frequency to pile up over the range of frequency above the base frequency. Default is +2dB.

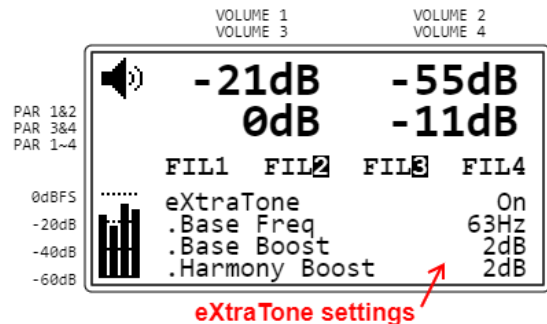

NOTE: The strength of Base Boost and Harmony Boost is actually dynamically controlled by the processor in the amplifier. For example, a setting of +2dB Base Boost may actually boost audio in base frequency up to 6dB if the input level is -30dB from its 0dBFS; while hardly more than 1dB if the input level almost reaches its 0dBFS. The mechanism prevents the amplifier from overdrive, while it also makes sense that the weak audio always requires more bass boost in the real world.

Furthermore, you have the option to enable the eXtraTone™ function along with a filter configured for bass or subwoofer speakers, so that you can further extend the bass performance of your bass or subwoofer speaker into the band of insanely ultra low frequency. The overall frequency response might look like the illustration on the right.

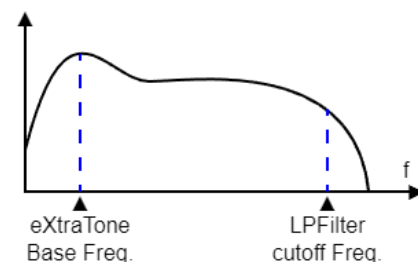

UNiKA UD-154 & UD-084 Switching Power Amplifier

Power Output Interface

The amplifier outputs are routed to reliable and robust speakON sockets with quick lock feature. The output of channel 2 is also routed to contact 2+/2- of speakON1 for Bi-Amp speaker connection. Similarly, the output of channel 4 is also routed to contact 2+/2- of speakON3 for the same purpose. The contact 2+/2- of both speakON2 and speakON4 are left unconnected. See an illustration for regular single-ended (SE) and Bi-Amp speaker connections on the right.

	speakON 1	speakON 2	speakON 3	speakON 4
contacts 1+/1-	CH1	CH2	CH3	CH4
contacts 2+/2-	CH2	N.C.	CH4	N.C.

Since the UD-154/UD-084 amplifier is designed to be able to drive heavy load with impedance down to 4Ω, each output of the amplifier can connect to a bunch of parallelized speakers with equivalent impedance as low as 4Ω. Most speakers with speakON sockets offer a pass through socket for the parallelizing, so audio technicians can easily achieve the parallelizing of a bunch of speakers via cables with speakON plugs.



NOTE: Please be informed that **all the outputs of UD-154/UD-084 amplifier are actually internally bridged outputs. They do not anymore support bridging externally.**

Due to the benefit of the internal bridge, the maximum power can be delivered from each speakON output of the amplifier is independent of the load (effective impedance of either 8Ω or 4Ω) connected to the output.

- UD-154: The maximum power can be delivered to a speakON output, however, is restricted to about 1.5KW, due to the limited capability of the power supply dedicated to that channel.
- UD-084: The maximum power can be delivered to a speakON output, in contrast, is restricted to about 750W, due to the fact that two adjacent channels of couple are driven by the same 1.5KW power supply. The UD-084 amplifier, however, has an option to deliver maximum power up to 1.5KW to a channel output if it is the only channel of the couple of the adjacent channels with connected load. That is to say, the outputs of adjacent channels of couple can be: 750W+750W, 1500W+0W, 0W+1500W, or other combinations with a total of 1500W. See the following illustration.

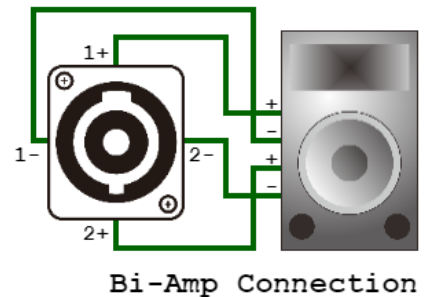
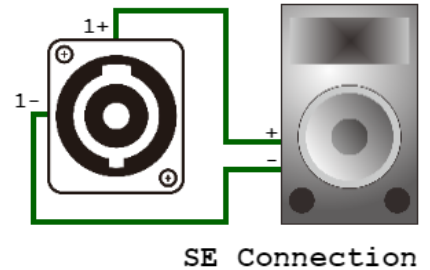
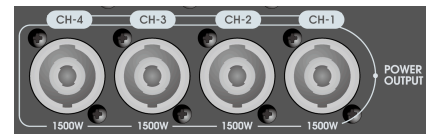
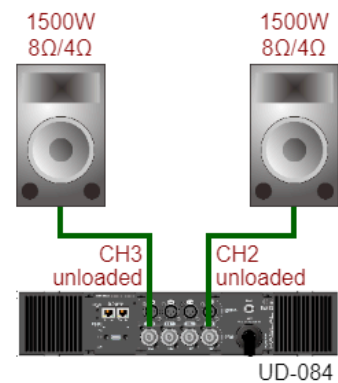
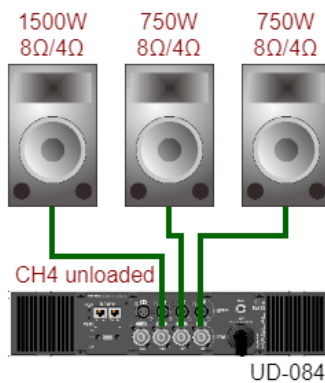
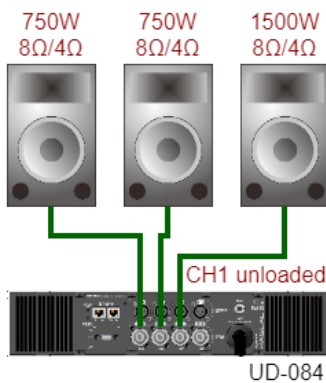

UNiKA UD-154 & UD-084 Switching Power Amplifier

Analog Audio Inputs

By default, the UD-154/UD-084 amplifier is configured to receive audio from analog inputs via balanced XLR sockets on the rear panel. The maximum acceptable signal level to the XLR input sockets is 24dBu, and input sensitivity to drive the amplifier to its 0dBFS maximum output can be set from the Sensitivity setting item in the SETTINGS menu mentioned previously.

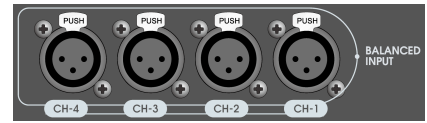

The signal wiring on the contacts of XLR socket is exactly the same as industrial standard as follows,

1. Signal Ground
2. Signal +
3. Signal -

Enabling **Parallel 1~4** will internally disconnect Input2, Input3, and Input4 to avoid possible noise coupling from the unused inputs.

USB Computer Interface



An USB2.0 port on the rear panel is used for firmware upgrade on the factory side. Currently it is not intended to be used for any application on the user side. Also, this belongs to a peripheral port and does not offer the capability of delivering 5V power.

UNiKA UD-154 & UD-084 Switching Power Amplifier

Dante Audio Network Interface:

The UD-154/UD-084 amplifier adopts Audinate Dante networking technology for AoIP (Audio over IP) receiving. When the amplifier sources the input from Dante audio network, a Dante icon, instead of speaker icon, is shown on the upper left of the VOLUME menu on the display to remind users that the digital audio from Dante network is selected as input. See the illustration on the right for an example.

The UD-154/UD-084 amplifier is by default configured to source audio from analog inputs via XLR sockets. To source digital audio from the Dante interface via RJ-45 ports, you need to switch the INPUT setting item from Analog to Dante in the SETTINGS menu, as illustrated on the right.

The Dante interface is very network friendly with unlimited flexibility in topology of deployment. It supports up to Layer 3 of IEEE 802.3 network standard, enabling you to organize your audio network with the on-the-shelf Ethernet switches/routers or to immediately transport streaming audio by taking advantage of your existing installed network facility with no hassle. Even better, the UD-154/UD-084 amplifier comes with two Ethernet ports which allow you to physically cascade several UD-154/UD-084 amplifiers in the same network link without an extra switch in between. Accompanying with Ethernet switches, this capability helps UD-154/UD-084 amplifier gaining flexibility and expanding territory in device deployment in audio networking.

The sample rate, as well as other configurations such as device name and etc., for the Dante interface of UD-154/UD-084 amplifier are set via computer with dedicated Dante Controller software. The assignment of audio routing between UD-154/UD-084 amplifiers and all the other Dante-enabled devices in the same Dante network is also set via the Dante Controller software. If you have a Dante Virtual Soundcard software installed in a computer (or in the same computer), you are even able to arrange the audio routing with Dante Controller software to have your DAW software direct play streaming audio to UD-154/UD-084 amplifier.

The Dante Controller software is available free for download from the following Audinate webpage,

www.getdante.com/products/software-essentials/dante-controller

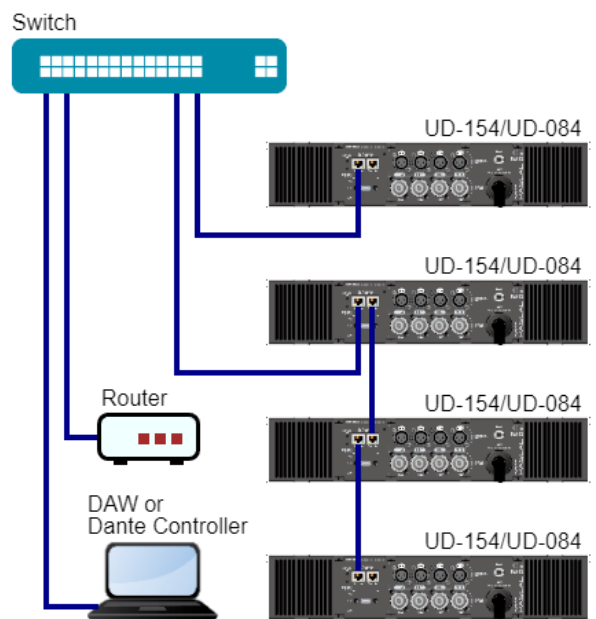
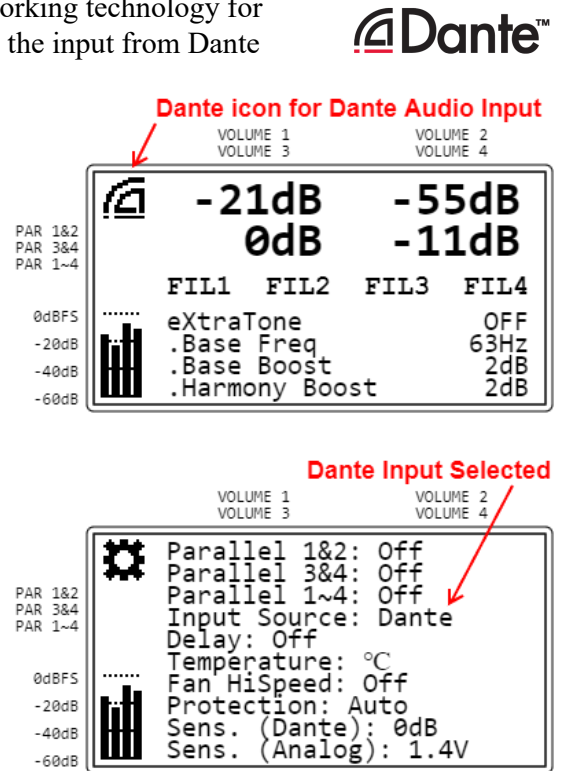

Among all the configuration and routing assignments in Dante Controller software, most importantly, **you should set the operating sample rate of your UD-154/UD-084 amplifier to align with the sample rate of your whole Dante network.** Basically, all the devices in the same Dante network should be synced to the same sample rate. You do not need to worry about the bit-depth of coding of your audio stream in network. Although the UD-154/UD-084 amplifier decodes audio in 24-bit PCM stream, it automatically does bit-depth converting when it streams audio from other Dante-enabled devices manipulating audio data in different bit-depth.

UNiKA UD-154 & UD-084 Switching Power Amplifier

Overview | Description | Getting Started | Configuration | Filter & eXtraTone | Out & In | **Dante** | Applications | Specifications | Warranty

There are two LEDs on each of the RJ-45 ports for the Dante interface. The LEDs reveal the network status described as follows,

- Amber: 1Gbps network is detected
- Green: flashing in network activity

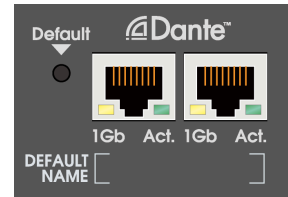

A DEFAULT button next to RJ-45 ports is used to restore the Dante configuration of the UD-154/UD-084 amplifier to its factory default. Press and hold the button when you power up the amplifier will restore the Dante interface to its default state. Once you hold the button for more than 5 seconds after you press the power switch, you can then release the DEFAULT button and re-power the amplifier for the default settings to take effect. The cap of the DEFAULT button is sunk to panel to avoid your accidentally triggering the action of default restoring.

Every Dante-enabled device has a unique Dante name for identifying in the Dante network. You can find the factory assigned Dante default name on a label in an enclosure of DEFAULT NAME below the RJ-45 ports for Dante Interface of your UD-154/UD-084 amplifier. The Dante name of the Dante interface of your amplifier can be changed to whatever you like by using Dante Controller software.

Usually, UTP (Unshielded Twisted Pair) Cat.5e cable should be good enough for all the network installation for UD-154/UD-084 amplifier. However, STP (Shielded Twisted Pair) cable is strongly recommended if you plan to route the cable through a noisy environment. The foil or braided screens in STP cable can provide great noise immunity from electromagnetic interference around. Also, make sure the EIA/TIA-568B standard is fully followed on the wiring of RJ-45 plug, as illustration on the right.

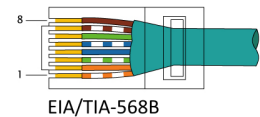

UNiKA UD-154 & UD-084 Switching Power Amplifier

Applications:

Dante Networking without Switch

One of the beauties of Dante is that you do not need a DHCP server or router in between to establish all kinds of communication among different Dante-enabled devices. Since the UD-154/UD-084 amplifier comes with two RJ-45 Ethernet ports, you can even simply cascade all your UD-154/UD-084 amplifier to your computer and digital console without any Ethernet switch in between.

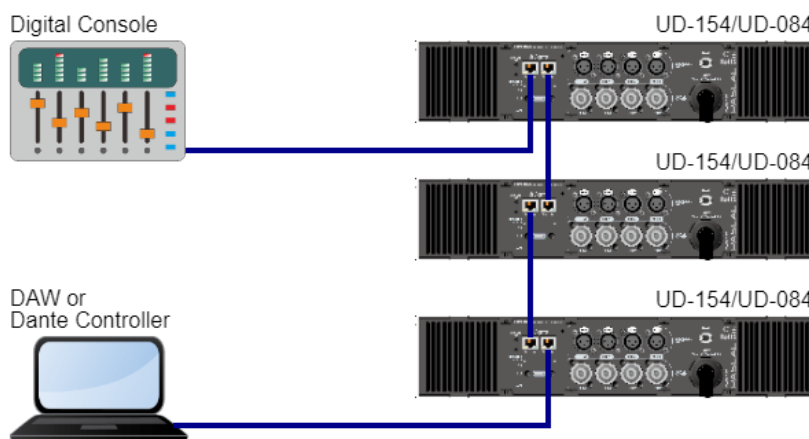

Dante Networking with Switches

Once your audio network grows up and turns complex, you may want to add Ethernet switches in your audio network so that you can better manage the cabling among all your Dante-enabled devices. For a large-scale system, you may even have many Ethernet switches in your audio network. The switches, including the mini switch in UD-154/UD-084 amplifier, do cause propagation delay but fortunately every one of them only contribute delay in several tens of microseconds.

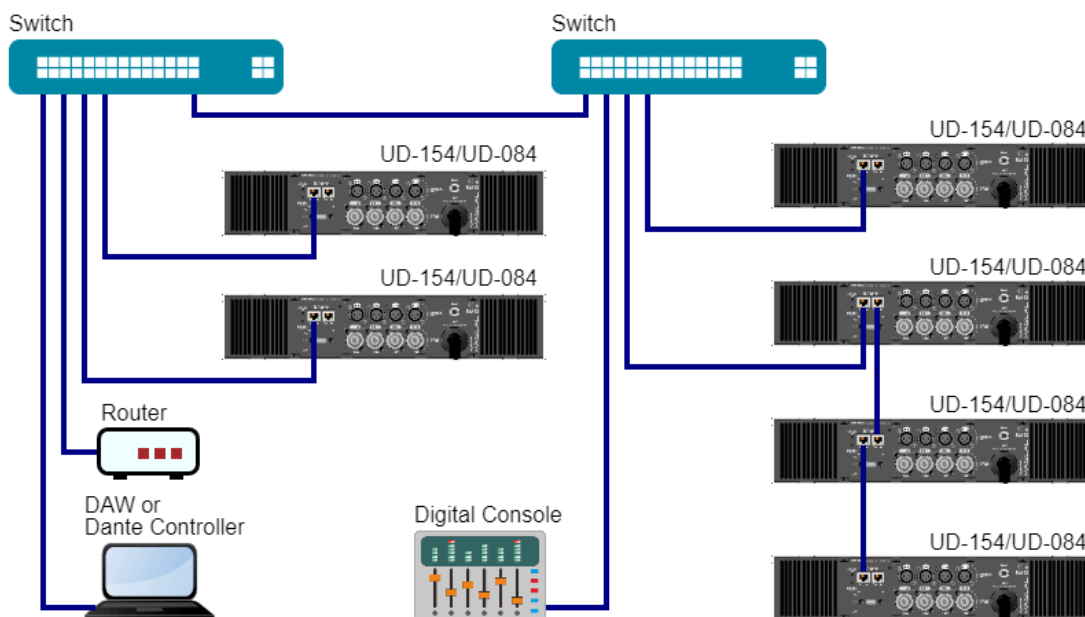

Putting a router somewhere in the Dante network is very helpful for simplifying IP management.

UNiKA UD-154 & UD-084 Switching Power Amplifier

Power Output to Speakers

There are lots of variety of output configurations that can be achieved through the high driving capability and high connection flexibility of the outputs of the UD-154/UD-084 amplifier. Every output of the amplifier can drive a bunch of parallelized speakers with equivalent impedance as low as 4Ω. Overall, the maximum power can deliver to a speakON output of UD-154 amplifier is 1.5KW; while the total power can deliver to a couple of adjacent speakON outputs of UD-084 is also 1.5KW but with flexibility of (750W + 750W) or uneven (1500W + 0W, 1500W + 0W, or other combination with total of 1500W) power distribution.

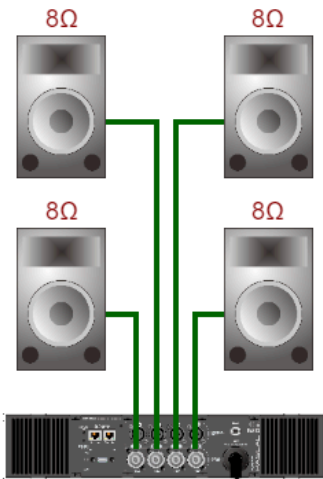

UD-154: 1500W x 4
UD-084: 750W x 4

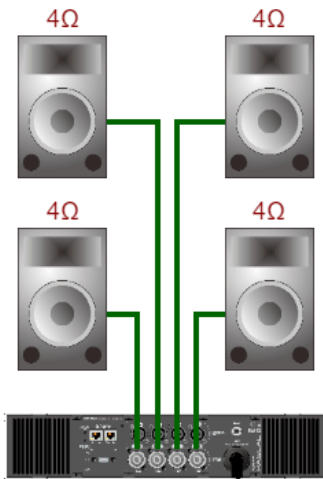

UD-154: 1500W x 4
UD-084: 750W x 4

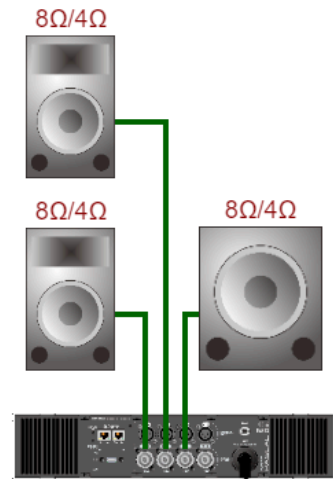

UD-084: 750W x 2 + 1500W

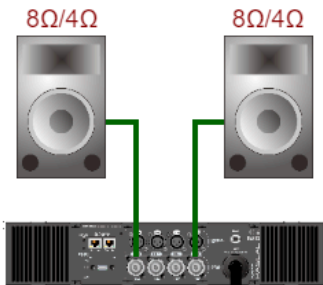

UD-084: 1500W x 2

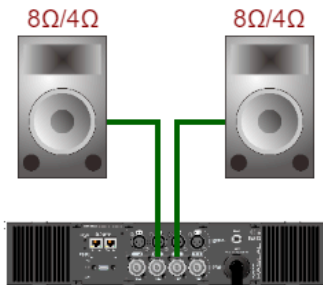

UD-084: 1500W x 2

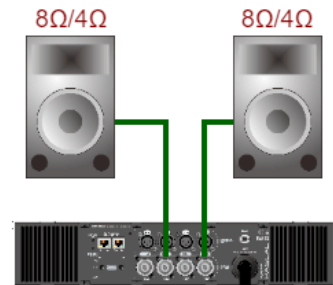

UD-084: 1500W x 2

UNIKA UD-154 & UD-084 Switching Power Amplifier

Output to Line Array

The UD-154/UD-084 amplifier is initially designed to seamlessly work with line arrays. Audio technicians can efficiently manage the amplifier's output capability to each speaker of the line array.

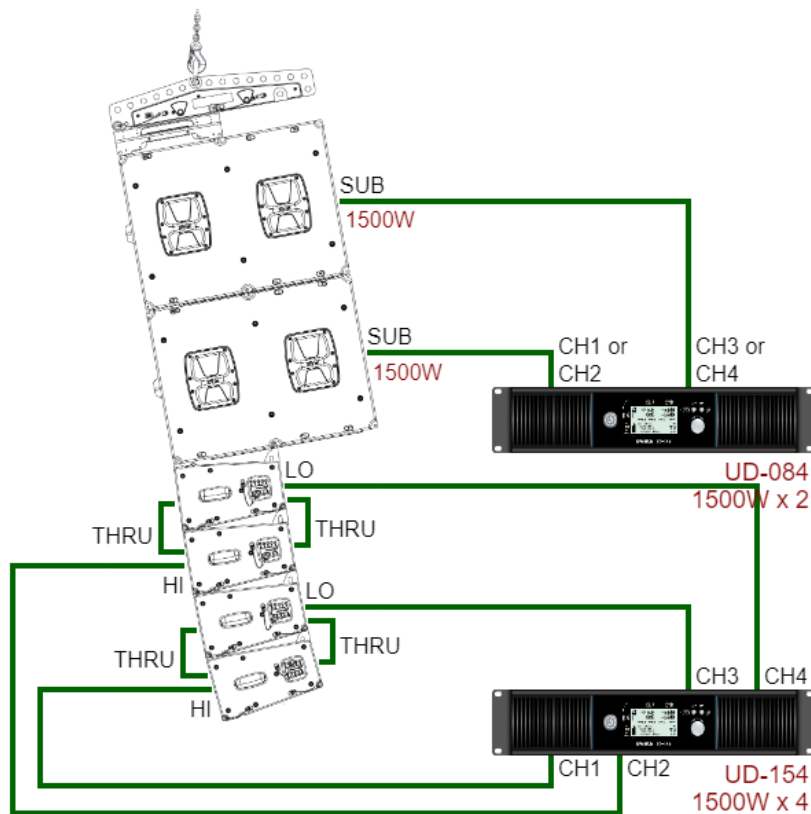
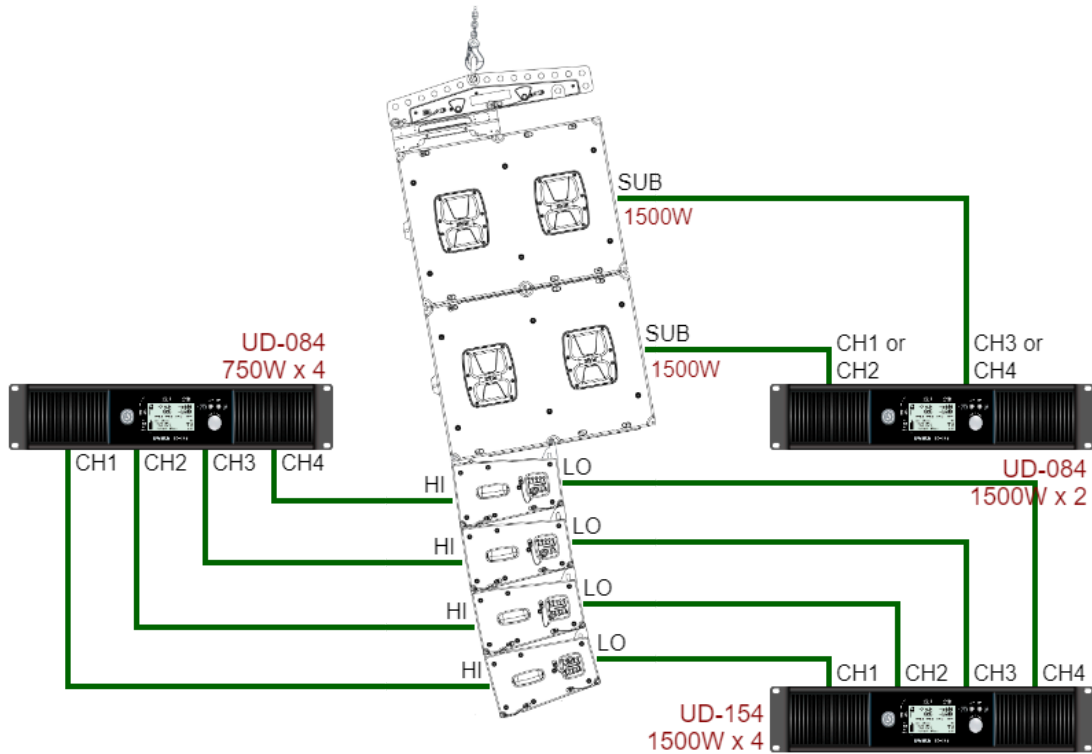

UNiKA UD-154 & UD-084 Switching Power Amplifier

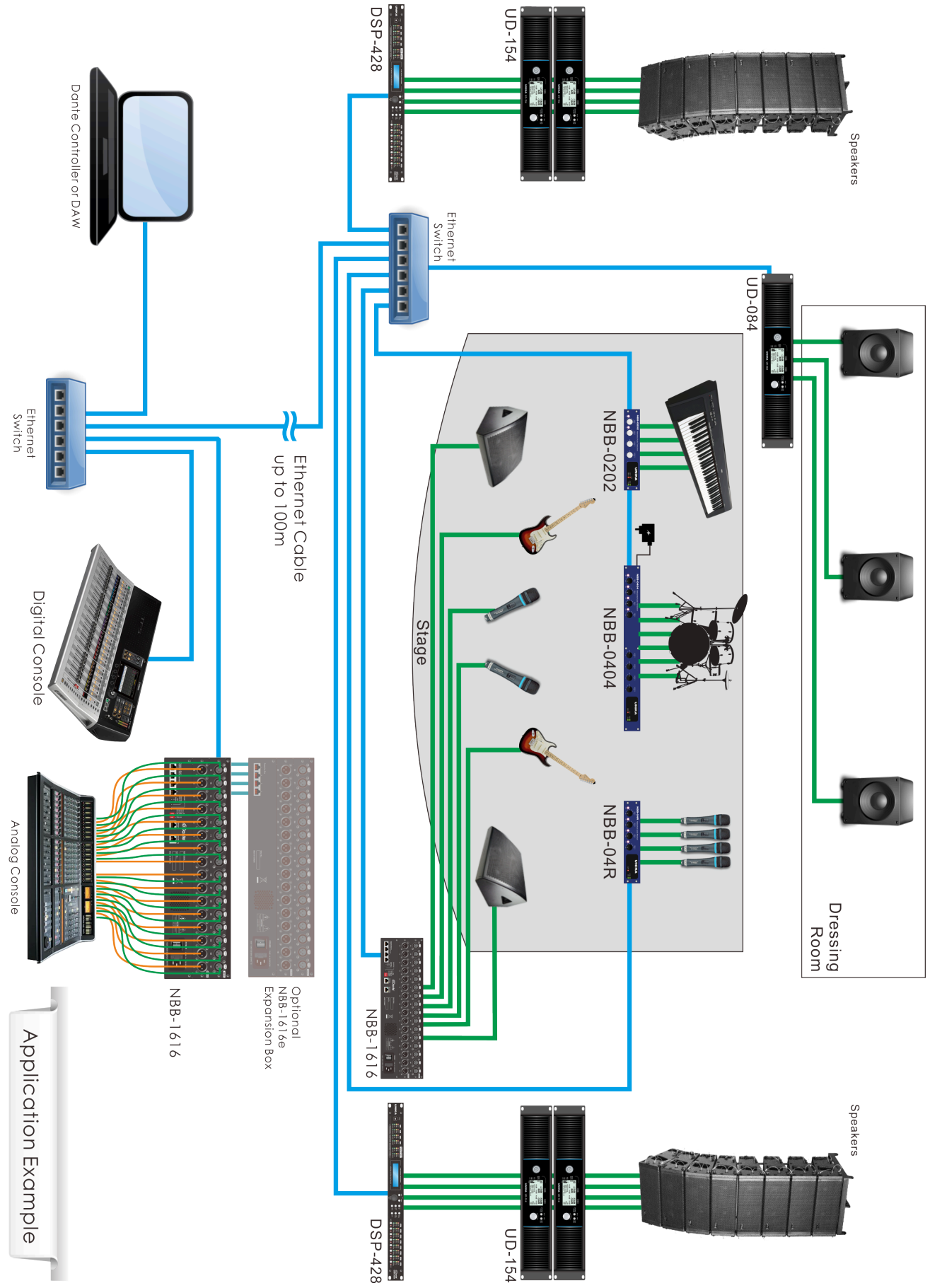

Application Example

UNIKA UD-154 & UD-084 Switching Power Amplifier

Overview	Description	Getting Started	Configuration	Filter & eXtraTone	Out & In	Dante	Applications	Specifications	Warranty
----------	-------------	-----------------	---------------	--------------------	----------	-------	--------------	----------------	----------

Specifications:

Model	UD-154		UD-084		
Output (< 1% THD)	AC240V	1400W@8Ω	1300W@4Ω	750W@8Ω	700W@4Ω
	AC220V	1350W@8Ω	1250W@4Ω	750W@8Ω	700W@4Ω
	AC127V	1400W@8Ω	1250W@4Ω	750W@8Ω	675W@4Ω
	AC120V	1400W@8Ω	1250W@4Ω	750W@8Ω	675W@4Ω
	AC110V	1350W@8Ω	1200W@4Ω	725W@8Ω	675W@4Ω
	AC100V	1250W@8Ω	1100W@4Ω	700W@8Ω	650W@4Ω
Output Configurations	4x BTL		4x BTL		
Output Connector	4x speakON				
Input Connector	4x XLR for Analog 2x RJ-45 for Dante				
Analog Input Impedance	22KΩ Balanced				
Analog Input Level	24dBu max.				
Analog Input Sensitivity	0dBu (0.775V) / 1V / 1.4V / 6dBu / 12dBu / 18dBu / 24dBu				
Dante Input Sensitivity	-24dB / -18dB / -12dB / -6dB / 0dB				
Volume Control	-60 ~ 0dBFS per Channel				
Delay Control	0 ~ 157ms per Channel				
PPM meter with clip hold	32 segments per channel				
Digitized Scaling	0dBFS at maximum output				
Audio Encoding	Uncompressed 24-bit PCM				
Sample Rate (Audio Process)	48KHz				
Sample Rate (Dante Interface)	44.1KHz / 48KHz / 96KHz				
Ethernet	2x Gigabit RJ-45 Ports				
Networking Mode	Switch Mode (a.k.a. Daisy-chain)				
Dante Audio Latency	< 2ms typical				
Dante Node to Node Distance	100m with Cat.5e Cable				
Gain (Dante @0dBFS)	43.5dB				
Gain (Analog @sensitivity 1.4V)	38.2dB				
Digital Filter per Channel	x6 2nd Order subfilters 2x 4th Order subfilters				
Frequency Response	20Hz ~ 20KHz ±1dB @-3dBFS				
S/N Ratio (A-weighting)	> 92dB @0dBFS				
THD + Noise (A-weighting)	< 0.05% @-3dBFS				
Dynamic Range (A-weighting)	> 90dB				
Crosstalk (Rated Output)	< -80dB @1KHz				
Output Impedance (20~1000Hz)	< 20mΩ				
AC Voltage	100~240V Full Range				
AC Power Consumption	< 1650Watts				
AC Power Factor	> 0.95@-3dBFS				
Operation Temperature	0 ~ 40°C				
Operation Rel. Humidity	0 ~ 90%				
Construction	Metal Chassis				
Dimensions (HxWxD)	88mm x 483mm x 434mm				
Net Weight	13.5Kg		12.5Kg		

All the result are tested under load of 4Ω and AC source of 120V/60Hz or 240V/50Hz if not specified.
The above information is subject to change without notice.

UNiKA UD-154 & UD-084 Switching Power Amplifier

Cautions and Important Safety Instructions

- minimum distances around the apparatus for sufficient ventilation.
- the ventilation should not be impeded by covering the ventilation openings with items, such as newspapers, table-cloths, curtains, etc..
- no naked flame sources, such as lighted candles, should be placed on the apparatus.
- the use of apparatus in tropical and/or moderate climates.

WARRANTY CONDITIONS

UNiKA products are designed and manufactured in Taiwan to the highest quality standard. However, if something does go wrong with a product, UNiKA Electronic Co., Ltd. will repair or replace such product in accordance with this warranty policy in any country served by an authorized UNiKA distributor. This warranty complements any national or regional law obligations of dealers, partner or national distributors and does not affect your statutory rights as a consumer. This warranty will only apply to products purchased from a legal UNiKA distributor or dealer, partner etc. This warranty will be effective from the serial number and initial date of purchase and will be valid for the warranty periods detailed as distributor's sales and service document. No claim under this warranty will be valid unless accompanied by proof of purchase of the product to which the warranty claim relates. This warranty is transferable from owner to owner and will apply and remain with the product to which it relates from the initial date of purchase for the specified term in the distributor's Area, as long as it's supported with the original proof of purchase.



UNiKA Service and Warranty Form

Model	<input type="checkbox"/> UD-154 <input type="checkbox"/> UD-084	Date	
User/Buyer information			
Company		Contact	
Tel		Fax	
Website		eMail	
Distributor/Dealer			
Contact		Remark	
Warranty valid date			
Signature and Stamp			