

NBB-1616 Networked Break-in/Break-out Box

NBB-1616e Expansion Box



Contents:

- Overview
- Description
- Getting Started
- Dante
- FAQ
- Front
- Rear
- Applications
- Specifications
- Warranty

UNiKA Electronic Co., Ltd.

www.unika.com.tw

6F, No.168, XinHu 2nd Road,
NeiHu Dist., Taipei 11494,
Taiwan (R.O.C.)

☎ +886-2-27933017

✉ unika@unika.com.tw

The latest version of this manual with color illustration is available for download from our product pages below,
www.unika.com.tw/products-view.php?ID=139 (English)
tw.unika.com.tw/products-view.php?ID=139 (繁體)

09/11/2024

Overview:

The NBB-1616 is a fully digitized 16 x 16 Break-in/Break-out box which bidirectionally streams multi-channel audio throughout off-the-shelf Ethernet cables and switches. The NBB-1616 is designed to be operated friendly and installed easily as well as system scalable and upgradable. The front panel features 16 clip-hold PPM meters for all the input or output channels. You have control over the audio volume and phase as well as the phantom power engagement individually for all the input channels locally on the front panel.

Features:

- 16 x 16 fully digitized Break-in/Break-out box
- Dante-enabled networked breakbox or stagebox
- Streaming audio in robust standard Ethernet cable (a.k.a., Digital Snake)
- Supports Layer 3 of IEEE 802.3 Ethernet standard, which means
- Streaming through Layer-3 Ethernet switch is feasible
- Easily organize network topology with regular Ethernet switches
- Redundant networking mode for fault tolerant audio distribution, or
- Daisy-chain networking mode for easy coverage extending
- Audio routing can be set by Dante-enabled audio console, or
- Dedicated Dante Controller software for Windows and Mac OS
- 24-bit PCM coding with sample rate up to 192KHz
- PPM meter with clip hold for input/output level monitoring
- Option to double channel capacity with a NBB-1616e expansion box
- Support of the latest feature of DDM with router involved

Description:

The NBB-1616 breakbox can be used as a stagebox and direct transceives audio to/from all kind of Dante-enabled audio consoles or DAW workstations in digital domain. With a dedicated P2P Pairing button on rear panel, two NBB-1616s can even be one-to-one paired to work as a digital snake which bidirectionally transceives audio throughout a regular Ethernet cable without the need of audio console or computer involved. All the routing configuration and device setting are automatically saved and preserved upon power recycle.

The NBB-1616 breakbox adopts Audinate Dante networking technology for audio transceiving, and is very network friendly with unlimited flexibility in topology of deployment. It supports up to Layer 3 of IEEE 802.3 network standard, enabling you to organize your audio network with the on-the-shelf



Ethernet switches or to immediately transport streaming audio by taking advantage of your existing installed network facility with no hassle. Even better, every NBB-1616 breakbox comes with two Ethernet ports which allow you to physically cascade several NBB-1616s in the same network link. You can also configure the two Ethernet ports to work independently but parallelly, which means you can redundantly route two links for seamless network backing up of each other. This drastically gains flexibility or reliability in device deployment for audio networking.

Audio routing among NBB-1616s and all the Dante-enabled consoles or workstations can be configured via computer with dedicated Dante Controller software which is available free from Audinate website. With Dante Virtual Soundcard software, you are even able to have your DAW software direct record/play multitrack streaming audio from/to NBB-1616 breakbox.

The audio input and output interfaces of NBB-1616 breakbox fully meet the requirements of the professional audio industry. Audio is encoded with the latest and uncompressed 24-bit PCM encoder with sample rate in 48KHz, 96KHz, or even up to 192KHz for extremely exquisite applications. The outputs are peculiarly buffered with amplifiers of high-rail-voltage which can drive the lines up to 24dBu. In addition to the high-level of drive capability on outputs, all inputs of NBB-1616 breakbox accept accept signal in a wide range from MIC level to LINE level with individual input gain and phantom power control. The NBB-1616 is also equipped with 16 PPM meters with clip hold functionality for all the input or output channels. This feature we think is very important for the audio technicians to simultaneously monitor all the input levels from clipping.

The NBB-1616 breakbox is regularly shipped with channel capacity of 16 analog inputs and 16 analog outputs (i.e., 16 x 16 I/O). However, it is not restricted itself here and you have the option to double the channel capacity for additional 16 x 16 I/O with an expansion box. With the box, you therefore can consolidate totally 32 x 32 audio into the same Ethernet cable.

Furthermore, the NBB-1616 breakbox is firmware upgradeable to support AES67 audio transport on request.

UNiKA NBB-1616 & NBB-1616e Networked Break-in/Break-out Box

Getting Started Guide:

Powering On

During power-on, the meter panel is blanked initially. The whole system is ready to work after a UNiKA (see the picture below) shown on the meter panel for about 3 seconds.

Do not power on the device immediately following a power off. At least wait for 10 seconds before you re-power the device. Fail to do so can make the power supply in the device restart from unknown state.

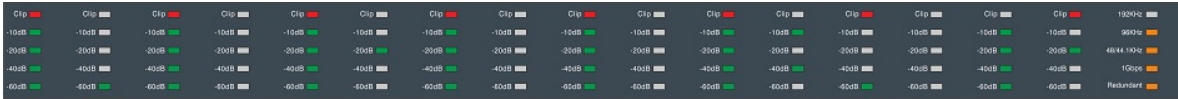

Sample Rate Setting

Every device in a Dante network must be configured to work in the same sample rate. Set the first two DIP switches on the rear panel to determine what sample rate you need, then long press the Sample Rate set button until you see a SET (see the picture below) shown on the meter panel. You will see the sample rate status LED on the front panel reflecting the setting you expect. Please be notified that the sample rate can be changed by computer running Dante

Controller software or Dante-enabled audio consoles. To determine what the sample rate is adopted in the device, please always look into the sample rate status LED on the front panel. The position of DIP switches on the rear panel is not necessary to be an indicator of the sample rate adopted in the device.

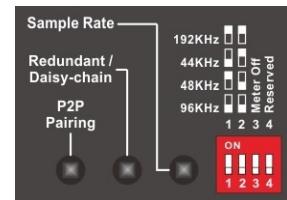

Redundant Mode:

There are two Dante network ports in the device. By default, these two ports are configured to work in switch mode (a.k.a. Daisy-chain mode). In switch mode, the streaming audio data going into any one of the ports will also switch forward out to the other port, and vice versa. That means you can simply treat these two ports as loop-in/loop-out ports, but bidirectional. That is to say, you can cascade several NBB-1616s in the same network link if their Dante ports are all configured to work in switch mode.

You may want to configure the two network ports to work in redundant mode to gain the benefit of reliability. To toggle the mode setting, simply long press the Redundant/Daisy-chain button on the rear panel until you see a SET shown on the meter panel. The device will be restarted itself and come out with the mode toggled. You can confirm whether the mode is changed by looking into the Redundant status LED on the front panel.

In the redundant mode, the two network ports work virtually independently but the audio transceived over them are exactly the same. That means you are redundantly routing audio over two network links and the two links are backing up each other. If any one of the link fails, the audio won't be interrupted because the other link can keep streaming the audio seamlessly.

One-to-One Pairing

You can configure two NBB-1616s to work as a digital snake right out of the box without any other computer or console in between. Simply connect the two NBB-1616s with a Ethernet cable and long press the P2P Pairing button on the rear panel until a SET shown on the meter panel, the two NBB-1616s are

UNiKA NBB-1616 & NBB-1616e Networked Break-in/Break-out Box

then automatically paired to each other with channel mapping in one-to-one style. At the end of the pairing process, you will see the paired result (see the picture below) on the meter panel. The every LED on the top row of the meter panel indicates if the particular input channel is successfully paired to its peer output channel from the other device, while the every LED on the bottom row indicates if the particular output channel is paired to its peer input channel in the other device. For example, the following picture is showing the NBB-1616 successfully pairing to the other device in all 16x16 I/O channels.



Network

Since two NBB-1616s may likely consume about 50Mbps of network bandwidth for 16x16 audio transceiving in sample rate of 96KHz, it is strongly recommended that all the network facilities used for the Dante networking meet the requirement of Gigabit throughput. I.e., **the Ethernet cables used for connecting must be in Cat.5e grade at least, while the switches to route the streaming audio must be Gigabit switches.**

Also, **do not use switches with EEE enabled.** EEE (Energy Efficient Ethernet) is a technology that reduces switch power consumption during periods of low network traffic. It is also sometimes known as Green Ethernet and IEEE802.3az. Although power management should be negotiated automatically in switches that support EEE, it is a relatively new technology, and some switches do not perform the negotiation properly. This may cause EEE to be enabled in Dante networks when it is not appropriate, resulting in poor synchronisation performance and occasional dropouts. If you want to use unmanageable switches, do not use Ethernet switches that support the EEE function, because you cannot disable EEE operation in these switches.

Usually, UTP (Unshielded Twisted Pair) Cat.5e cable should be good enough for all the network installation. However, STP (Shielded Twisted Pair) Cat.5e cable is strongly recommended if you plan to route the cable through noisy environment. The foil or braided screens in STP cable can provide great noise immunity from electromagnetic interference around. Also, make sure the EIA/TIA-568B standard is fully followed for the wiring of RJ-45 plug.

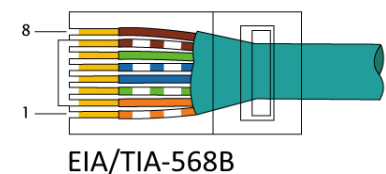

Latency

In Dante, variation in latency in the network is compensated for at the receiver. Each receiver has a device latency setting which can be set by the user with Dante Controller software. This setting defines the latency between the timestamps on the incoming audio samples and when those samples are played out. The default latency for the NBB-1616 is 1 msec, which makes the audio latency in the whole signal path (i.e., from audio input of one NBB-1616 to the audio output of the other NBB-1616) less than 1.5ms typical. This is very acceptable in a live sound situation. For whatever reason you can set the device receive latency to as low as 250µs if there is no more than one Ethernet switch in between. With the setting, the audio latency in the whole signal path will then be down to less than 500µs.

Audio Level

To suppress the digitizing quantum noise and gain the most benefit of high dynamic range from data converters, **it is good practice to maintain audio level around -20dBFS in Dante network.** Since both input and output levels of NBB-1616 are nominated at +24dBu full scale, the -20dB from digital full scale level is +4dBu which exactly aligns to the 0VU (+4dBu also) level in analog world. The signal path of every input channel of NBB-1616 breakbox features dedicated PPM meter and volume gain/pad control (mentioned below) which allow audio technicians to monitor and adjust audio level easily.

UNiKA NBB-1616 & NBB-1616e Networked Break-in/Break-out Box

Dante Master Clock and Syncing

Word Clock of digital audio is distributed throughout the whole Dante Network from a clock master. **There is one and only one device that can distribute the master clock in the whole Dante network.** The NBB-1616 breakbox by default starts up itself as a slave device and to be synced by the clock extracted from the Dante network. It can, however, be automatically elevated to be a clock master if there is no clock master in the network. From the Clock Status tab of Dante Controller software, you can identify which device is elevated to as clock master in the Dante network.

Setting Examples for Yamaha & Soundcraft Consoles

For an application with a digital audio console in the Dante network, you may want the console to be a clock master. I.e., the console internal clock clocks the Dante interface of the console, and then the Dante interface of the console distributes the master clock throughout the Dante network. If this is the case, you can simply configure the Dante interface of the console to be clocked by the internal clock of the console by enabling the SyncToExternal option in Dante Controller software. The Dante interface of the console will then be elevated to a clock master automatically. Below is an example of configuring the Yamaha MY16-AUD Dante interface card to be clocked by the internal clock of the console itself via Dante Controller software,

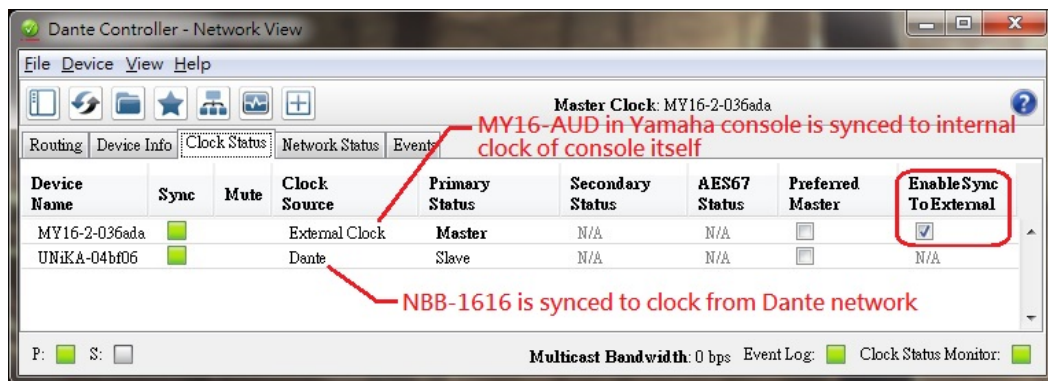

Please be notified that only one Dante interface of a console can be set to SyncToExternal if there are more than one consoles in the network. All the other Dante interfaces of consoles should be instead synced to the clock from Dante network. And you should also go to the setup pages of these consoles and manually configure the word clocks of these consoles to be synced to the clocks from Dante interfaces respectively. Below is an example of setting of the source of the word clock for Yamaha LS9 digital console. The left one shows the word clock of the console is synced to the internal clock of the console itself so that the console itself become a clock master; while the right one shows the word clock is synced to the MY16-AUD Dante interface card in the console so the console itself is no longer be a clock master.

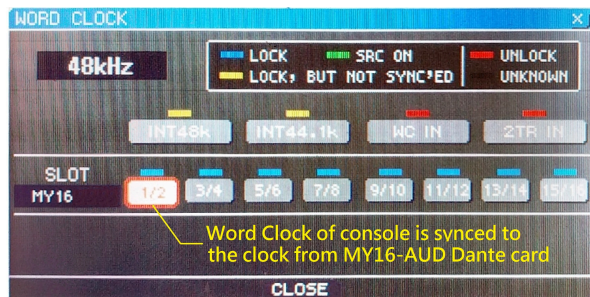
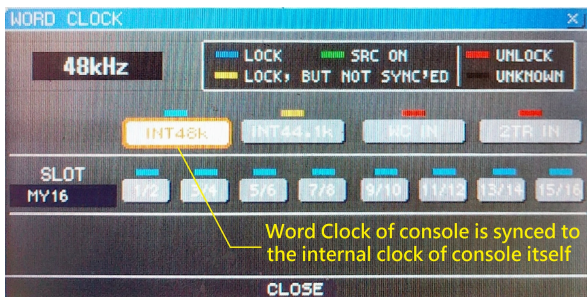

UNiKA NBB-1616 & NBB-1616e Networked Break-in/Break-out Box

Overview | Description | Getting Started | **Dante** | FAQ | Front | Rear | Applications | Specifications | Warranty

Similarly, if you have the NBB-1616 to work with a Soundcraft Dante-enabled console, you need to make sure the source of the word clock of the console is set properly by accessing the Sync tab in the console's main MENU screen on master bay. Here is an example of settings for Soundcraft Vi3000 console.



Please be informed that the Vi 3000 local MADi and Dante ports share an input and so are exclusive. You also have to choose the DANTE as active input from the DANTE/MADI global switch in the Settings tab of the main MENU screen.

UNiKA NBB-1616 & NBB-1616e Networked Break-in/Break-out Box

Dante Controller:

Dante Controller is a free software application that enables you to route audio and configure devices on a Dante network. With automatic device discovery, one-click signal routing and user-editable device and channel labels, setting up a Dante network couldn't be easier.

Dante Controller is much more than just a configuration and routing matrix. Dante Controller provides essential device status information and powerful real-time network monitoring, including device-level latency and clock stability stats, multicast bandwidth usage, and customized event logging, enabling you to quickly identify and resolve any potential network issues. You can also quickly and easily backup, restore, move, and reuse Dante network configurations using Presets, and edit Dante routing configurations offline.

Dante Controller is available for Windows and Mac OS X, and can be downloaded from Audinate website below,

www.audinate.com/products/software/dante-controller

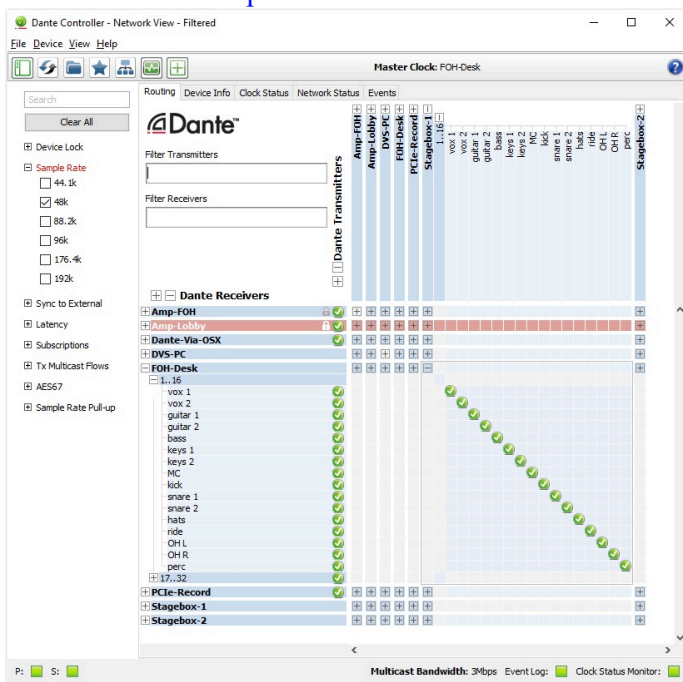

Besides Dante Controller, you may be also interested in software of Dante Virtual Soundcard and Dante Via, which can transceive audio between your computer and Dante network. More information can be found on their product webpages below,

www.audinate.com/products/software/dante-virtual-soundcard

www.audinate.com/products/software/dante-via

About Dante

Dante audio networking utilizes standard IP networks to transmit high-quality, uncompressed audio with near-zero latency. It's the most economical, versatile, and easy-to-use audio networking solution, and is scalable from simple installations to large-capacity networks running thousands of audio channels. Dante can replace multiple analog or multicore cables with a single affordable Ethernet cable to transmit high quality multi-channel audio safely and reliably. With Dante software, the network can be easily expanded and reconfigured with just a few mouse clicks. Dante is the audio networking choice of nearly all professional audio manufacturers, with hundreds of Dante-enabled audio products now available.



Designed to fully exploit the capabilities of today's and tomorrow's networking equipment, Dante provides media transport mechanisms that eliminate many traditional audio network design restrictions. Dante makes it easy to set up robust, flexible digital audio networks with virtually unrestricted performance. A Dante network can be designed with mixed Gigabit and 100Mbps network speeds, and simultaneously support audio with different bit depths.

Dante is built on Internet Protocols - not just Ethernet. Because it uses standard IP over Ethernet, Dante is capable of running on inexpensive off-the-shelf computer networking hardware, and with the use of standard QoS can share installed networks with other data and computing traffic.

Dante provides sample-accurate synchronization and can deliver the very low latency required by professional audio. Dante's network-centric, audio-independent approach to synchronization allows perfectly synchronized playout across different audio channels, devices and networks, even over multiple switch hops.

Dante makes networking a true plug-and-play process, allowing automatic device discovery and system configuration. Dante-enabled devices will automatically setup their network configuration and advertise themselves and their channels on the network, reducing complicated, error-prone set-up procedures. Instead of "magic numbers", networked devices and their input and output signals can be named to make sense to the user.

For more information, please visit the Audinate website at www.audinate.com.

Frequently Asked Questions:

Q The NBB-1616 fails to power recycling. And the power indicator LED and the LEDs on the buttons keep flashing.

A This problem sometimes happens when the device has worked in a warmer environment for quite a long time. The high temperature in the device triggers the temperature protector in the device so that the device cannot startup normally. Simply turn off the device and wait for more than 20 seconds, you should be able to successfully startup the device again.

Q Why does the status LED for 48KHz, 96KHz, or 192KHz flash for every 2 seconds?

A This informs you that the NBB-1616 currently works in a sample rate of multiple of 44.1KHz, instead of multiple of 48KHz. That is to say, the device works in a sample rate of 44.1KHz, 88.2KHz, or 176.3KHz instead.

Q Why does the status LED of 1Gbps flash for a couple of seconds right after the device is powered on?

A The LED flashing indicates that the word clock of NBB-1616 is still not yet synced to the master clock from Dante network. Once the word clock of the NBB-1616 is successfully synced, the flashing ceases. Please be noted that the LED may keep flashing if the device is not linked to any Dante network.

Q Why does not the working sample rate of the NBB-1616 reflect the setting of DIP switches on the rear panel of the device?

A Besides the DIP switches on the rear panel, the working sample rate of the NBB-1616 can also be changed by other Dante-enabled controllers in the same network. For example, a computer running Dante Controller software can remotely configure the sample rate setting of NBB-1616. To figure out what the sample rate is actually selected in the device, please always look into the sample rate status LEDs on the front panel.

Q Why are not all the channels paired with channels on the remote device after I long press the P2P Pairing button?

A Sometimes the device on the remote site does not respond promptly so that some channels are not paired. Simply press the P2P Pairing button and try again should be able to have all channels paired with the channels on the remote site successfully.

Q After I long press the P2P Pairing button, the channels in the NBB-1616 are paired to the channels on the device which is not expected.

A NBB-1616 always looks for the other UNiKA device for channel pairing first. If it can't find any other UNiKA device in the network, the 1st device responding would be eligible for the channel pairing process. If your application requires to have the NBB-1616 to pair to a particular Dante-enabled device in the network, simply turn-off the other devices or unplug the RJ45 network cables to them before you long press the P2P Pairing button.

Q I long press the P2P Pairing button to start an auto pairing process, but it fails and ends with an ERR message.

A During the auto pairing process, the NBB-1616 browses the network and waits for 2 seconds to see if there is any Dante-enabled device in the network. Sometimes the device on the remote site might not promptly respond to the browsing message and the NBB-1616 may end the browsing process with an ERR message on the front panel. Simply press the P2P Pairing button again to launch another browsing activity, the NBB-1616 should be able to find the remote device and complete the auto pairing process.

Q Why is there no audio transferred?

A For any two devices to be able to transfer audio in between, both of the devices must work in the same sample rate and the word clocks of both devices must be synced to the same master clock from the Dante network. You can know the working sample rate of NBB-1616 from the sample rate status LEDs on the front panel. And the 1Gbps status LED flashes if the word clock of the NBB-1616 is neither

synced to a master clock nor eligible to be a clock master. For the other non-UNiKA devices which do not have dedicated status LED, you can still find their sample rate and syncing information from the Dante Controller software.

Q Why do I get intermittent sound?

A If the network traffic is not heavily congested, the problem is most likely caused by IP conflict. For example, if there is DHCP server or router in your network and if there are also one or more fixed-IP devices in your network, the NBB-1616 may be occasionally assigned with an IP which is permanently occupied by one of the fixed-IP devices in the network if the DHCP server or router does not recognize the existence of these fixed-IP devices. In the case, the audio streaming activities of the NBB-1616 can be frequently interrupted by the fixed-IP device. Please contact your MIS or IT people to deal with the IP conflict issue.

Q Why does the DAW or audio player in my computer sometimes can't play or record anything after I enable the Dante Virtual Soundcard (DVS)?

A DVS is a virtual soundcard which does not own necessary hardware to generate the master clock and therefore can't be a clock master in the Dante network. For the DAW or audio player to work in a computer with DVS launched, there must be at least one Dante-enabled device, e.g. NBB-1616, in the network to distribute the master clock. Also sometimes the DVS can't successfully startup if there is no master clock in the network. In this circumstance, you just have to restart the DVS after you are sure of the existence of the master clock in the network.

Q Why does the Dante Virtual Soundcard (DVS) cease working after I re-power the NBB-1616?

A Same reason as the answer above. The DVS won't work if it loses the master clock from the network. Sometimes the DVS can't recognize the resuming of the master clock promptly so that the DVS may seem to cease working for quite a long period of time. If this is the case, restarting the DVS can make it work immediately.

Q How does NBB-1616 achieve the HA Remote capability?

A When the NBB-1616 works as a stagebox and is connected to an audio console, it does not support the HA Remote protocol developed proprietarily by the console's manufacturer. Although the NBB-1616 does not support HA Remote from console, however, the front panel of NBB-1616 includes all the audio control functionalities such +48V phantom power engagement, 60dB sensitivity control, -18dB pad control, and phase inverting control. Moreover, the PPM meters on the front panel of NBB-1616 direct show you the input level of every channel individually, which allows the audio technicians on the stage to locally control and monitor the audio level to console. This can be better than to control and monitor the inputs on the stage remotely from the console.

Q How can I turn off the HA Remote functionality from the console?

A From Dante Controller software, double click the item to console Dante interface, you should be able to find a HA Remote tab from where you can turn off the HA Remote functionality.

Q Why can't I change Sample Rate, Switch/Redundant Mode, or complete a P2P pairing when the NBB-1616 is in managed domain?

A When a Dante device, including NBB-1616, is enrolled in a managed domain, the DDM has very tight control over the Dante device. All the settings can only be changed via Dante Controller with DDM password. If you need to control the settings with the three buttons on the rear of NBB-1616, you need to specially allow the local and remote access right to the NBB-1616 device by configuring it via the DDM control interface. For details, see the user guide below on the section of rear panel.

Q I forgot to un-enroll the NBB-1616 from a Domain before it disconnected from the managed environment, so the device does not work in my current unmanaged environment.

A To clear the Domain credentials in the NBB-1616, solely (i.e., no other dante device involved) connect it to your computer with Dante Controller running, and click the "clear Domain credentials" under the device drop down menu on device view window to the NBB-1616.

UNiKA NBB-1616 & NBB-1616e Networked Break-in/Break-out Box

[Overview](#)[Description](#)[Getting Started](#)[Dante](#)[FAQ](#)[Front](#)[Rear](#)[Applications](#)[Specifications](#)[Warranty](#)

Front Panel:

The front panel of NBB-1616 breakbox features 16 clip-hold PPM meters, 5 status LEDs, and several useful audio control capabilities.

Clip-Hold PPM Meters

To gain the most from digitized transceiving with high dynamic range and low noise floor, audio technicians always need to keep the audio level at decently large while avoiding over clip. Each of the 16 PPM meters consists of 5 LED indicators which let the audio technician easily monitor the level of input audio from clipping. The dedicated clip LED flashes and stays on for at least 2 seconds when the input audio level reaches 0dBFS (0dB Full Scale) instantaneously. This is especially useful for audio technicians to quickly identify the source of audio distortion by simply glimpsing the 16 clip LEDs on the panel.

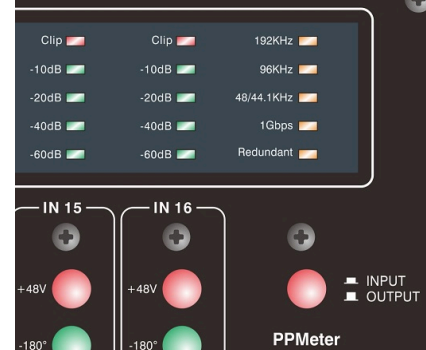

Besides measuring input audio, you are able to switch all the 16 meters to monitor level on output by simply pressing an INPUT/OUTPUT button on the far right of the front panel.

Also, you are able to turn off the metering function and dim all the level LEDs by a DIP switch setting on the rear panel.

Status LEDs

On the rightmost of front panel, there are 5 LED indicators showing the following operating information,

192KHz: indication of current sample rate of 192KHz. The LED may flash every 2 seconds if the sample rate is synchronized at 176.4KHz alternatively.

96KHz: indication of current sample rate of 96KHz. The LED may flash every 2 seconds if the sample rate is synchronized at 88.2KHz alternatively.

48KHz: indication of current sample rate of 48KHz. The NBB-1616 breakbox is by default configured to sample audio in 96KHz. The LED may flash every 2 seconds if the sample rate is synchronized at 44.1KHz alternatively.

1Gbps: indication of current active link of Ethernet cable is synced in Gigabit data rate. The LED may flash for every 2 seconds if neither its word clock is synced to a master clock nor it is elevated to a clock master in Dante network.

Redundant: indication of current network topology of the two RJ45 ports is configured to work in redundant mode. And it flashes every 2 seconds if any one of the RJ45 ports is link down. By default, the two network interfaces (two RJ45 ports) are configured to work in switch mode, i.e., daisy-chain mode.

All the above status LEDs can blink together for about 4 seconds if you momentarily press the IDENTIFY DEVICE button on the device view window in the Dante Controller. They can also blink when a software upgrade is progressing in the background. Please don't turn off its power until the upgrade is completed.

UNiKA NBB-1616 & NBB-1616e Networked Break-in/Break-out Box

[Overview](#)[Description](#)[Getting Started](#)[Dante](#)[FAQ](#)[Front](#)[Rear](#)[Applications](#)[Specifications](#)[Warranty](#)

Input Audio Control

To accommodate different audio sources with various signal properties, under the 16 PPM meters, it comes with several useful audio control facilities for every input signal path,

+48V: phantom power to power condenser microphone or other accessories such as DI box.

-180°: phase inverting to temporarily invert audio phasing for acoustic control.

-18dB: pad control to further attenuate signal strength for strong input signal.

Gain: volume knob of 0~60dB to control the amplification for weak signal from magneto-dynamic microphone.

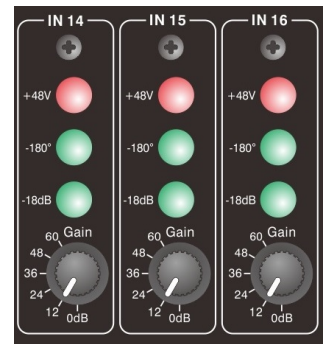

UNiKA NBB-1616 & NBB-1616e Networked Break-in/Break-out Box

[Overview](#)[Description](#)[Getting Started](#)[Dante](#)[FAQ](#)[Front](#)[Rear](#)[Applications](#)[Specifications](#)[Warranty](#)

Rear Panel:

Power Inlet and Fuse Holder:

The NBB-1616 breakbox can be powered by a wide range of AC source from 100~240V. The fuse in the fuse holder must be a slow blow type of fuse rated at 1A. **Do not use a fast acting fuse for replacement.** There is also a spare fuse in the fuse holder when the machine is shipped.

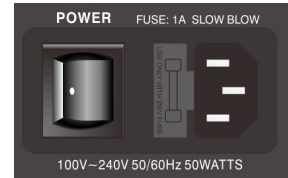

Fan Control:

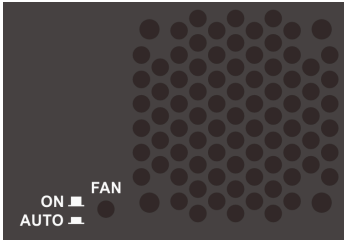

The fan on the rear of the NBB-1616 breakbox, by default, is always ON when the device is in operation. However, you have the option (AUTO MODE) to turn off the fan by pressing down the FAN switch through the little hole next to the fan. The fan then won't startup until the temperature in the device reaches 70°C. Once the fan turns on, it won't turn off until the device cools down below 40°C internally. The feature of AUTO ON/OFF allows people who operate the device in a quiet studio to avoid the wind noise from the fan.

We strongly recommend you leave the fan always ON, because keeping the device cool can evidently prolong the device lifetime in long term.

Dante Network Interfaces:

Under normal room environment, the NBB-1616 can transceives audio stream up to 100 meters with Cat.5e Ethernet cable or above. There are two RJ45 jacks on the rear panel for Dante audio networking. These two Ethernet interfaces can be configured to work as either switch mode or redundant mode.

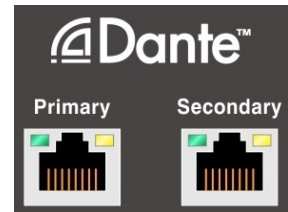

- **Switch Mode:** This is the default mode. Under switch mode configuration, you can cascade several NBB-1616s in daisy-chain topology. The major benefit for this mode is that you can easily extend the audio coverage with only one single Ethernet link by simply plug-in cable from previous NBB-1616 and plug-out cable to the jack in the next NBB-1616 in the same route. Since both primary and secondary of the RJ45 interfaces are virtually equal in switch mode, it does not matter whether you plug-in into the primary or secondary RJ45 jack first. However, **in switch mode, you can't connect two NBB-1616s with two cables from both primary and secondary interfaces of one device to the other device.** Doing so can cause an IP conflict error and crash the whole Dante network. Please refer to the "Daisy-chain" diagram of section of "Typical Deployment and Application" for illustration.
- **Redundant Mode:** This enforces fault tolerance by transceiving audio stream through two separated Ethernet networks. The data flowing in both RJ45 interfaces are redundant to each other but are transceived in absolutely separate routes. Therefore, any network failure on the primary side can be seamlessly recovered by the network on the secondary side, and vice versa. Please be notified, **never mix data paths between primary side and secondary side on any network node if the network interfaces are configured to work in redundant mode.** Doing so can crash both sides of networks and hang all NBB-1616s in both networks.

While configuring the NBB-1616 to work in switch mode can extend coverage easily by cascading several NBB-1616s in daisy-chain, you are also encouraged to extend your audio network with the on-the-shelf Ethernet switches. Since NBB-1616 breakbox can transceive data over Ethernet switches, you can easily and freely expand your audio streaming network with one or more Ethernet switches no matter if the two Ethernet interfaces in the NBB-1616 are configured to work as switch mode or redundant mode. Please refer to the section of "Typical Deployment and Application" for illustration.

UNiKA NBB-1616 & NBB-1616e Networked Break-in/Break-out Box

Overview | Description | Getting Started | Dante | FAQ | Front | **Rear** | Applications | Specifications | Warranty

You can toggle the above mode setting in between by simply long pressing a Redundant/Daisy-chain button on the rear panel. This is also mentioned in the next section of the guide.

DIP Switches and Set buttons:

There are 4 DIP switches and 3 set buttons on the rear panel of the NBB-1616 breakbox. With them, you are allowed to manipulate or setup the NBB-1616 breakbox without any controller or computer involved.

- **P2P Pairing** button: long-press the button for longer than 2 seconds or until a SET shown on the meter panel, the NBB-1616 enters P2P (peer-to-peer) pairing procedure. In the circumstance, the NBB-1616 browses or searches if there is any other NBB-1616 or other UNiKA device in the linked network. If there is any qualified device found, the NBB-1616 will try to subscribe to every channel on the remote device peer-to-peer, and vice versa. Which means, if successfully pairing, all the input and output channels of the local and remote devices are routed to each other in peer-to-peer style. The whole pairing process does not need any dedicated controller or computer in between. The whole process even does not need any DHCP server and Ethernet switch in between if you simply want to pair two NBB-1616s to transceive audio in between. That is to say, you can pair two NBB-1616s to properly work as digital snake right out of the box by simply connecting them with an Ethernet cable and pressing the P2P pairing button on one of the NBB-1616s.

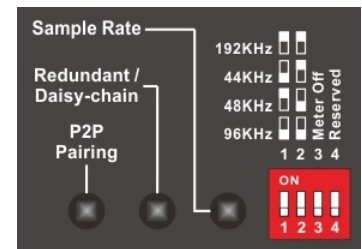

Note: During the pairing process, the NBB-1616 waits for 2 seconds to see if there is any other Dante-enabled device in the network. Sometimes, the NBB-1616 does not receive any response from the network in the time frame and can fail to complete the pairing process, even if there is actually one or more than one Dante-enabled devices in the network. In such circumstance, please feel free to try again by pressing the P2P Pairing button once again.

Note: If there is more than one Dante-enabled device in the network, the NBB-1616 breakbox randomly picks up one for pairing. If you need to have the NBB-1616 breakbox to be paired with a particular device, please temporarily remove all other devices from the network or simply turn them off temporarily.

Note: Two devices can transceive audio streams in between only if both of them are configured to manipulate audio in the same sample rate. The automatically pairing process of NBB-1616 can successfully pair itself to a device working in a different sample rate. Once the pairing process is complete, in this circumstance, the NBB-1616 will initial an instruction to the paired device to try to request a sample rate change in the paired device to match the sample rate setting of the NBB-1616 itself. However, the change request to the paired device may be discarded by the paired device for whatever reason. If this is the case, the audio stream will not be successfully transceived in between until you manually configure one of the pairing or paired devices to match the sample rate setting of the other.

Note: By default, the NBB-1616 encodes audio in PCM 24-bit. The NBB-1616 can pair to a device with PCM coding in bit depth other than 24-bit. The audio data is then left aligned during transceiving between devices with audio encoded in different bit depth. If NBB-1616 is transceiving audio stream with a device operating in 16-bit PCM coding, for example, the 16-bit audio data received from the paired device will be left shifted 8 bits and padded with 8 zero on the LSB side, whereas the 8 LSB bits of 24-bit audio data transmitted from NBB-1616 will be truncated to fit the 16-bit width in the paired device. I.e., the MSB side of data bits are always preserved and left justified.

UNiKA NBB-1616 & NBB-1616e Networked Break-in/Break-out Box

- **Redundant/Daisy-Chain** set button: long-press the button for longer than 2 seconds or until a SET shown on the meter panel, the NBB-1616 toggles network topology setting between switch (i.e., daisy-chain) mode and redundant mode. Since the NBB-1616 needs to reboot itself for the new setting to take effect, please be patient to wait until you see the Redundant status LED on the front panel toggled.

Note: Although toggling the Redundant/Daisy-Chain mode won't change the audio routing setting, you need to pay attention to make sure the network cabling is changed accordingly ahead of the mode change, otherwise you may crash the whole network. Basically, you can't mix cabling between primary network and secondary network in redundant mode; and you can't connect any two devices with two cables to both primary and secondary RJ45s simultaneously in switch/daisy-chain mode.

- **Sample Rate** set button: After determining the required sample rate with DIP switch 1 and 2, long-press the set button for longer than 2 seconds or until a SET shown on the meter panel, the NBB-1616 sets the audio sample rate accordingly. You can check whether the sample rate is set expectedly by observing the 192KHz/96KHz/48KHz status LEDs on the front panel.

Note: The NBB-1616 breakbox also supports the sample rate in multiple of 44.1KHz (i.e., 88.2KHz and 176.4KHz). However, for these rate settings, you need to set it through Dante Controller software instead. Also, the corresponding status LED for sample rate on the front panel flashes to notify you that the audio sample rate is synchronized in the multiple of 44.1KHz, instead of 48KHz.

There are currently only 3 DIP switches programmed in NBB-1616. The first two are used for sample rate setting as mentioned above. The DIP switch 3 is programmed to turn off the meter functionality and extinguish all the meter LEDs.

Note: On some NBB-1616s, the 4th DIP switch may be programmed to restrict the device browsing to UNiKA products only during the P2P pairing process. Enabling the feature can prevent the NBB-1616 to pair to a product manufactured by the company other than UNiKA during the automatic pairing process.

Note: All the function of the above three buttons can be disabled when the device is enrolled in a domain through DDM (Dante Domain Manager). To enable the function capabilities of these three buttons, you have to enable the Read/Write local controller access in the device detail page in DDM control interface. You also need to particularly assign operator to the remote controller role to enable the P2P Pairing button.



Dante Device Name:

Every Dante-enabled device has a unique device name so that the user can identify it with the friendly name instead of an always-changing network IP address. The device name must be unique and can't conflict with any name of the devices in the same network. Every NBB-1616 device is shipped with a default device name in the form UNiKA-xxxxxx, where the xxxxxx is the suffix of the MAC address of the particular NBB-1616. On the rear panel of NBB-1616, you can find its default device name on a tag above the device series number. Users can change the device name to whatever they like with the Dante Controller software or Dante-enabled digital console in the same network.



UNIKA NBB-1616 & NBB-1616e Networked Break-in/Break-out Box

Clear Configuration setting and System Reset:

For whatever reason, you may want to clear all the configuration settings to your NBB-1616 and reset the device to factory default. To do so, simply press the three set buttons (P2P Pairing, Redundant, and Sample Rate) on the rear panel momentarily and simultaneously. You will see a RST shown on the meter panel once you press the three set buttons. Please be patient to wait for the device to completely reboot by itself. Once reboot is completed, you should see a UNIKA briefly shown on the meter panel. Please be notified that the factory reset is not allowed when the NBB-1616 is enrolled in a domain.

Note: Reset the NBB-1616 will restore the device configuration to factory default as follows,

- Dante Device Name is reset to the default name shown on the tag on the rear panel.
- Redundant Mode is disable. I.e., the device can be cascaded in Daisy-Chain style.
- Preferred Master option is clear.
- Sample Rate is set to 48KHz.
- Receive Latency is set to 1ms.
- All channel subscriptions to other devices are removed.

Expansion Box Interface (RJ45 x 4):

On the leftmost of the rear panel, four RJ45 jacks constitute the expansion interface which is used to double channel capacity with an optional NBB-1616e expansion box. The expansion box can come with 16x16 analog I/O (available now), 16x16 AES/EBU digital I/O, or any combination of analog and digital I/O as per your request. The four cables between the expansion box and NBB-1616 breakbox should be qualified Cat.5e FTP shielded cables with length of each no more than 0.5m. The cable of longer than 0.5m can cause propagation delay issue for the digitized audio in the cable and results in high audio distortion of input channels.



Note: The expansion box does not support sample rate in 192KHz/176.4KHz due to the limitation on the CPU capability and higher propagation delay in the expansion interface.

Audio Interface (XLR3):

To meet the requirement for the professional audio industry, all the analog inputs and outputs are balanced with 0dBFS referenced at 24dBu. The digital -20dB level on the meter of the front panel is therefore exactly the same as the 0VU level (+4dBu) in the traditional analog world.

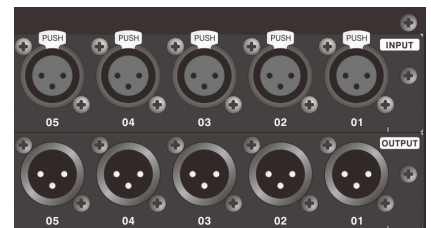

Note: To get flat frequency response, the balanced audio outputs are all direct and transformerless coupling. **Please do not short either pin 2 or pin 3 of any XLR to pin 1 of itself** if the output is destined at unbalanced input. You can, however, simply float pin 3 and drive the unbalanced input with pin 2 and pin 1 merely.

UNiKA NBB-1616 & NBB-1616e Networked Break-in/Break-out Box

Typical Deployment and Application:

Digital Snake Two NBB-1616s can be paired to work as a digital snake. Simply connect them with a Ethernet cable and long press the P2P Pairing button on the rear panel of any one the devices, the input and output channels of each device then be automatically and sequentially routed to the other device in one-to-one basis. With expansion box, you can even consolidate 32x32 channels totally to be transceived in a single Ethernet cable.

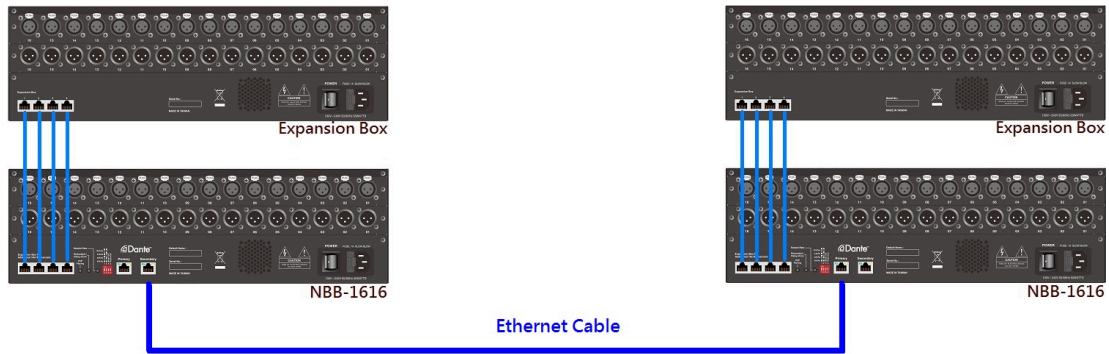

Stagebox With a Dante-enabled audio console, you can have the NBB-1616 to work as a stagebox. The console can then route multi-channel audio to/from NBB-1616 on remote site with a single Ethernet cable. Similarly, you can also have your DAW software to transceive multi-channel audio to/from NBB-1616 if your DAW software also supports Dante networking or if you have Dante Virtual Soundcard installed along with your DAW software.

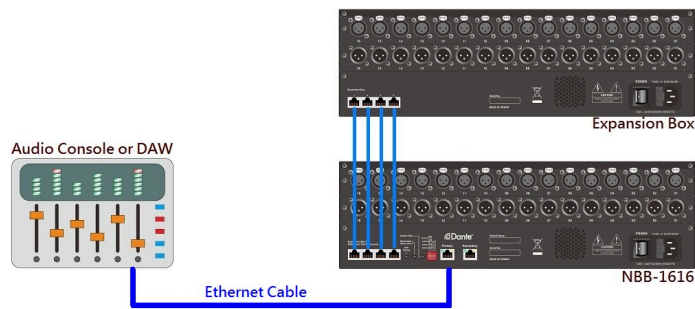

Daisy-chain With the two network ports configured to work in switch mode, you can cascade several NBB-1616s in a same link. This greatly simplifies the network wiring and devices deployment if you need to route audio to several spots sequentially.



UNIKA NBB-1616 & NBB-1616e Networked Break-in/Break-out Box

Redundant For fault tolerant deployment, you can configured the two network ports in NBB-1616 to work in redundant mode. The two separated network links can then backup each other if any one of the links fails for whatever reason.

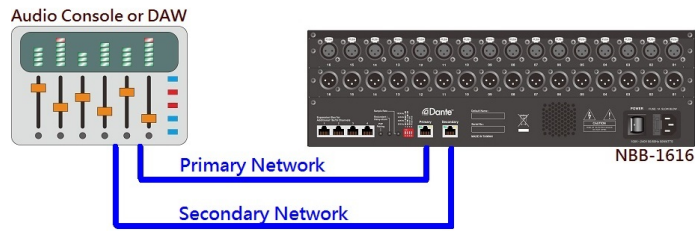

System Scaling Up Since NBB-1616 can stream audio data throughout the Ethernet switch, you can deploy your NBB-1616s through the switch with a minimum of data collision.

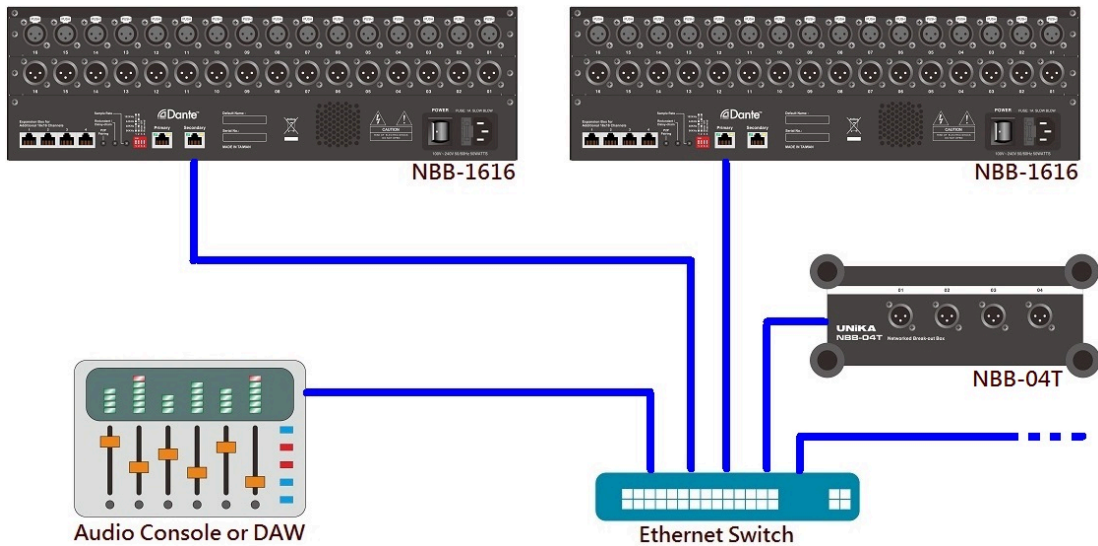

System Scaling Up Computer network can be further expanded with more than one Ethernet switch, so does NBB-1616 audio network. You can use more than one switch between NBB-1616s to greatly expand your audio distribution.

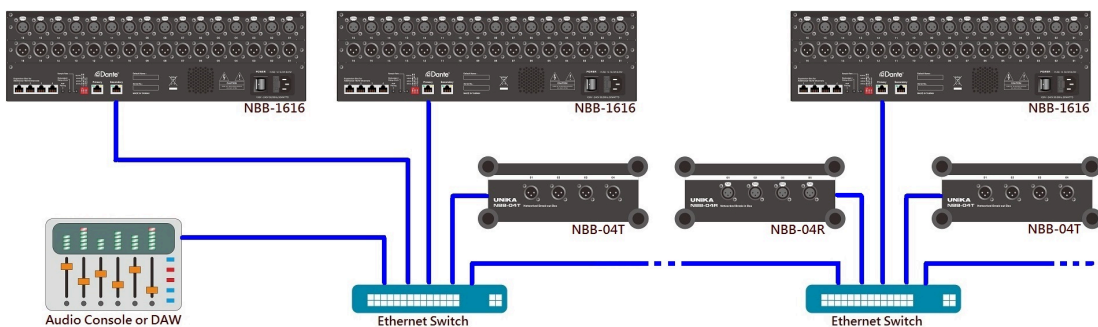

UNiKA NBB-1616 & NBB-1616e Networked Break-in/Break-out Box

System Scaling Up with Redundancy By configuring all the NBB-1616s to work in Redundant mode, you can simultaneously stream your audio to two virtually independent networks to significantly improve fault tolerance.

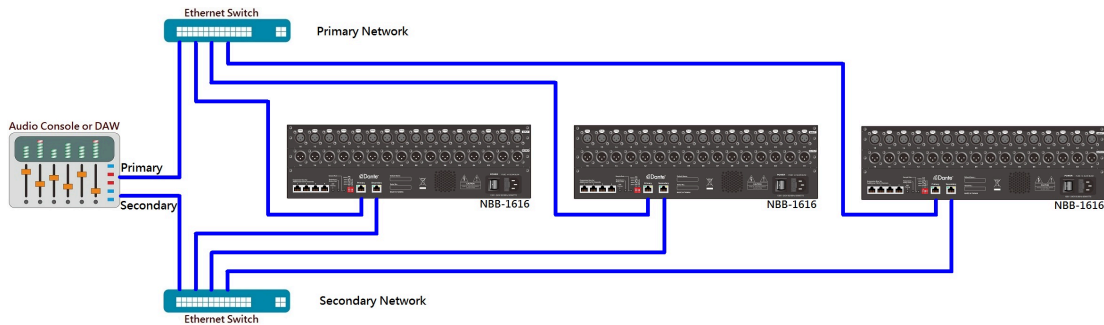

Extending Coverage with Fiber Optic To break the 100m limitation of Cat5.e Ethernet cable, the switches with fiber optic support can be adopted to extend the coverage to more than several hundreds of meters or even several kilometers.

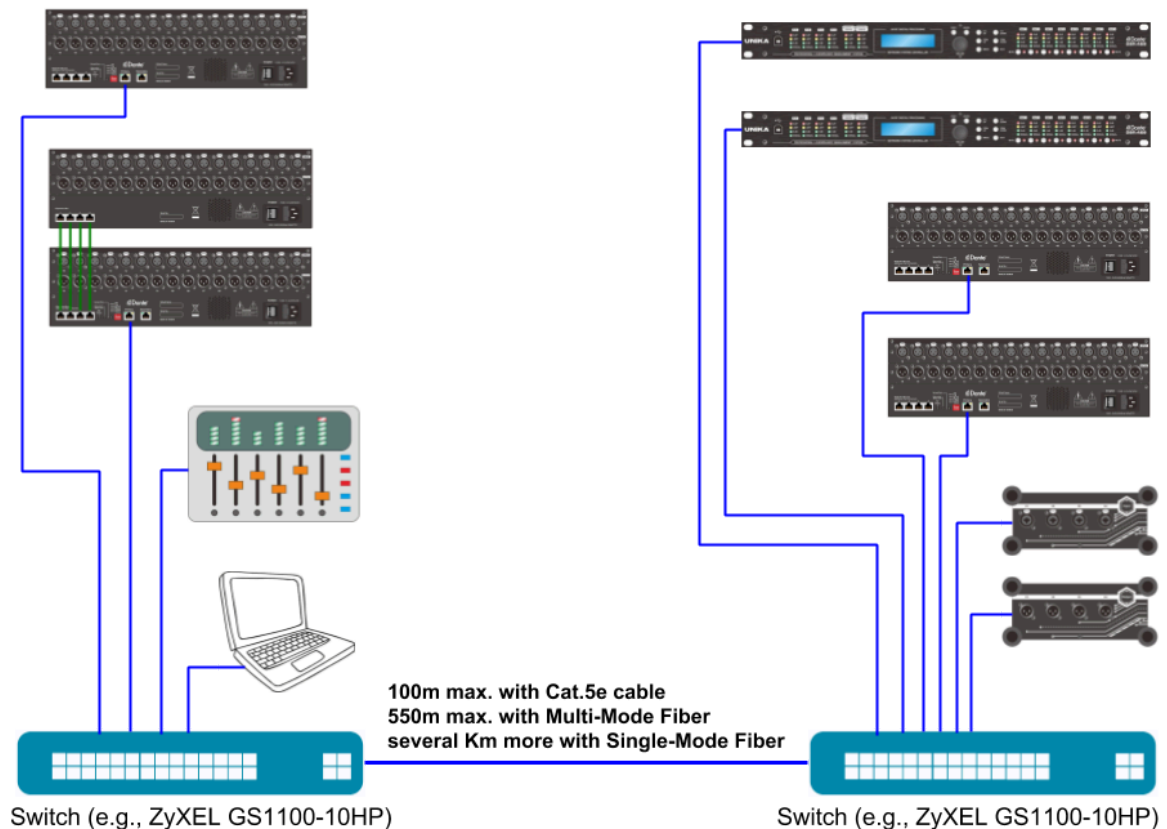

UNiKA NBB-1616 & NBB-1616e Networked Break-in/Break-out Box

Application Example

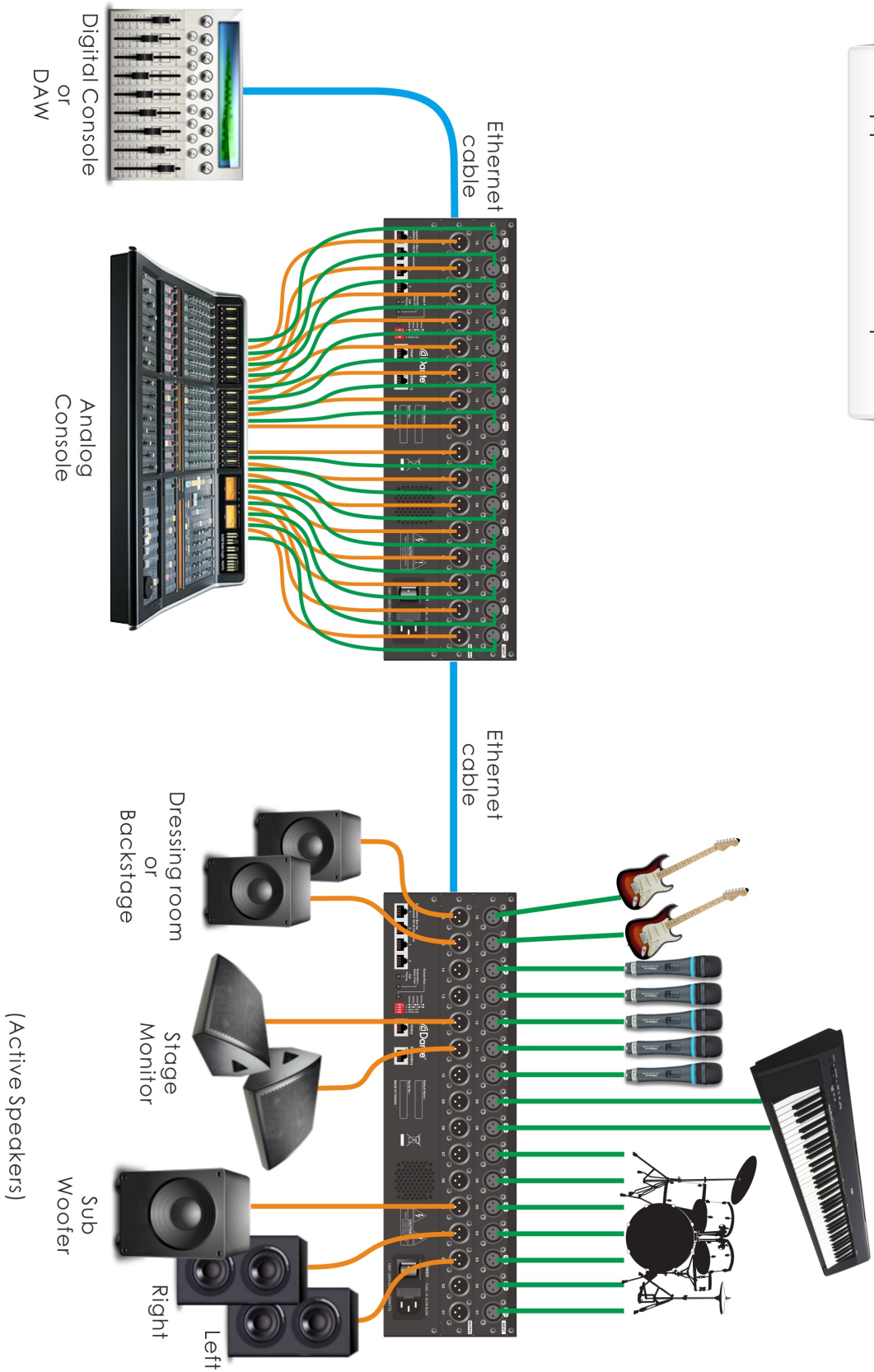

UNiKA NBB-1616 & NBB-1616e Networked Break-in/Break-out Box

Application Example

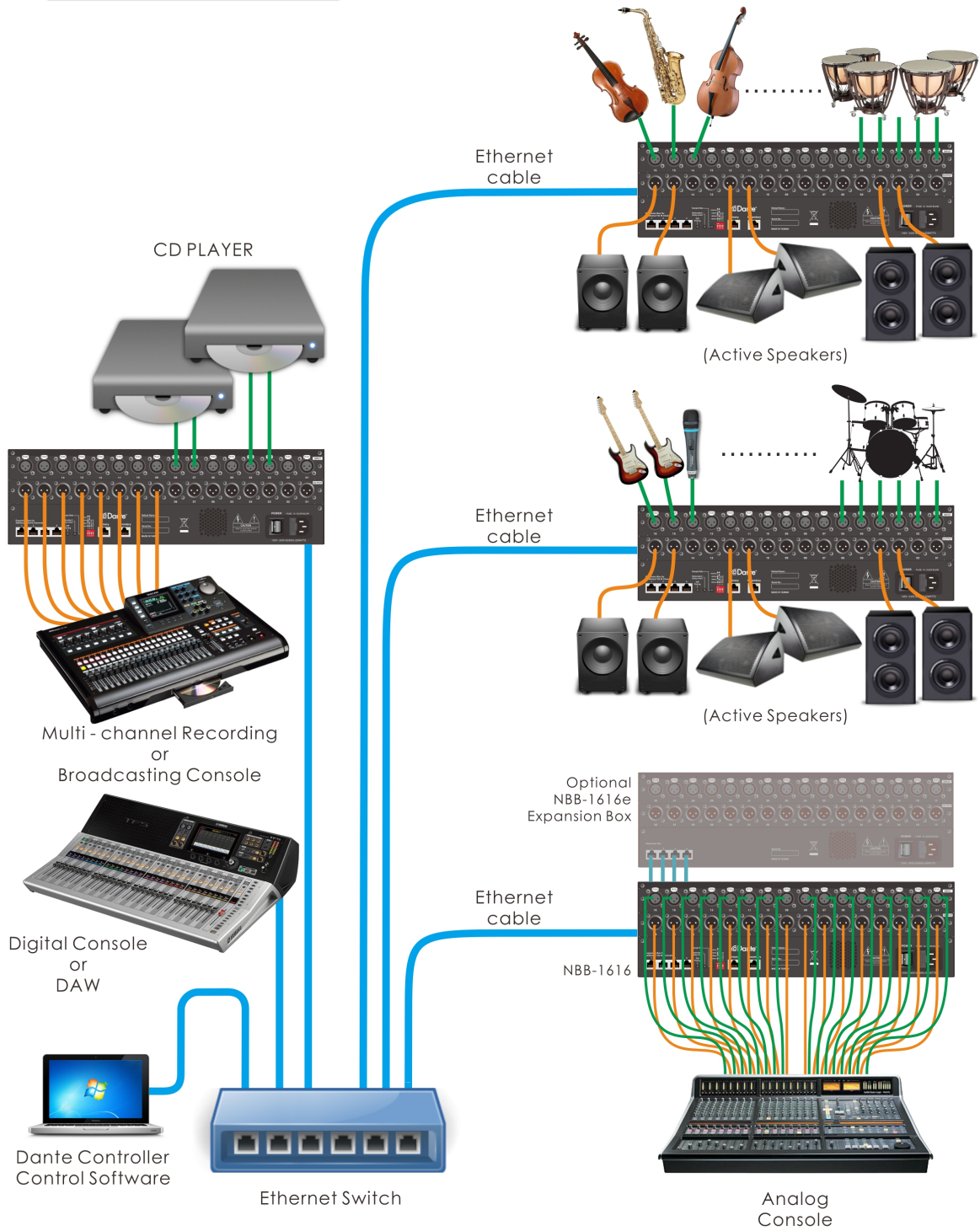

UNiKA NBB-1616 & NBB-1616e Networked Break-in/Break-out Box

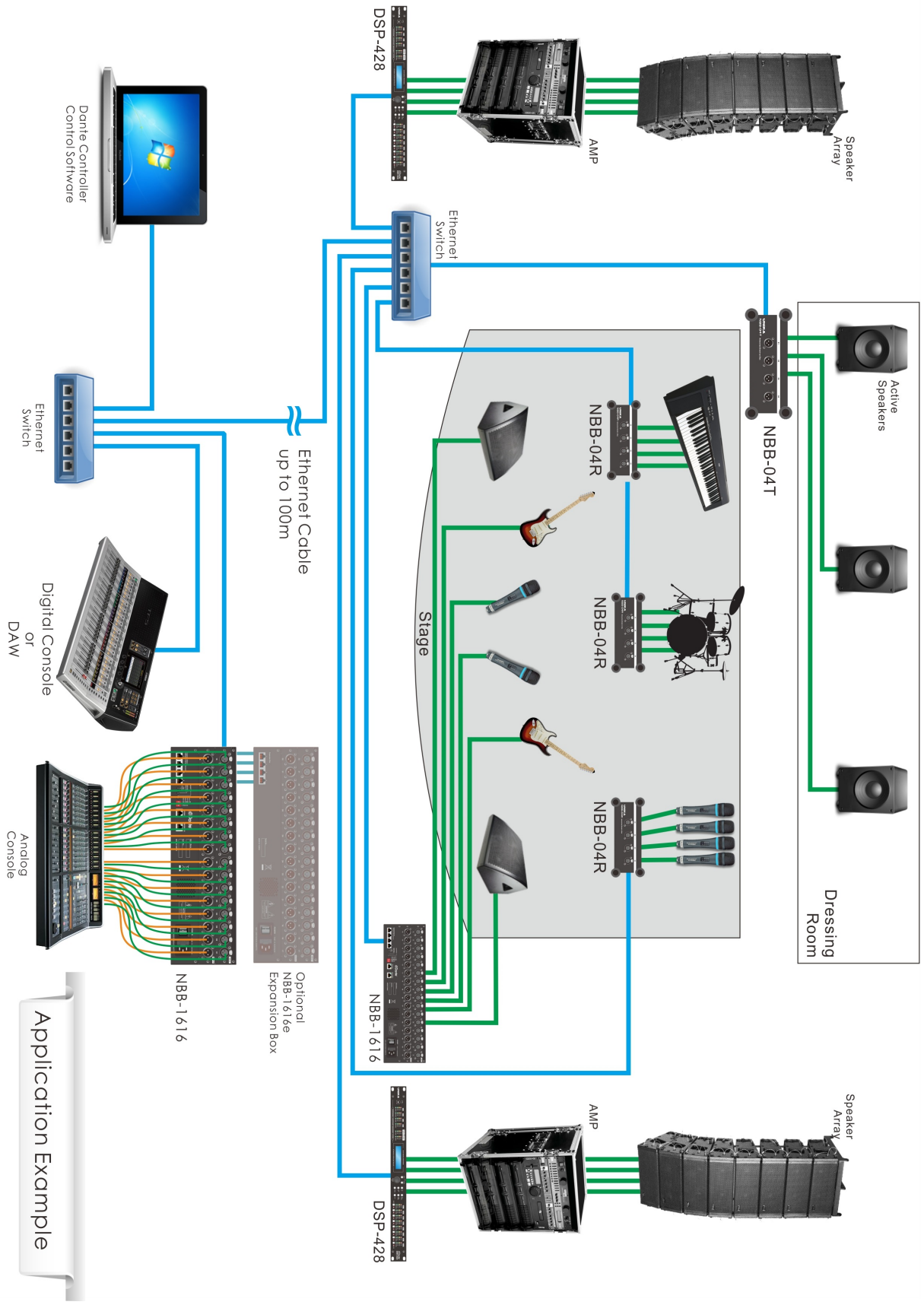

Application Example

UNiKA NBB-1616 & NBB-1616e Networked Break-in/Break-out Box

[Overview](#)[Description](#)[Getting Started](#)[Dante](#)[FAQ](#)[Front](#)[Rear](#)[Applications](#)[Specifications](#)[Warranty](#)

Specifications:

Model	NBB-1616
Channel Capacity	16 (Input) x 16 (Output)
Level Meter	PPM Meter with Clip Hold
Meters Scaling	0dBFS @24dBu
Output	24dBu max., Balanced XLR
Input	42dBu max., Balanced XLR
Input Phase Control	180° Inverting Control
Input Gain Control	60dB Rotary and -18dB Pad Control
+48V Phantom Power	ON/OFF Control per Input
Encoding	Uncompressed 24-bit PCM
Sample Rate	44.1KHz / 48KHz / 96KHz / 192KHz
Ethernet	2x Gigabit RJ45 Ports
Networking Mode	Redundant or Daisy-chain
Transmission Distance	> 100m with Cat.5e Cable
Audio Flows	32x (unicast + multicast)
Audio Latency	< 2ms typical
Frequency Response	20Hz ~ 20KHz ±0.5dB
S/N Ratio (Input)	> 110dB @0dBFS
S/N Ratio (Output)	> 110dB @0dBFS
THD + Noise (Input)	< 0.002% @-10dBFS
THD + Noise (Output)	< 0.001% @-10dBFS
Dynamic Range	> 110dB
Crosstalk (Input)	< -95dB @10KHz
Crosstalk (Output)	< -120dB @10KHz
Operating Voltage	100 ~ 240VAC, 50/60Hz
Power Consumption	< 50Watts
Operation Temperature	0 ~ 45°C
Operation Relative Humidity	0 ~ 90%
Construction	3U Rack-Mount Chassis
Dimensions (HxWxD)	133mm x 480mm x 250mm
Weight	7Kg

All the above test result are measured with no signal weighting.

The above information is subject to change without notice.

UNiKA NBB-1616 & NBB-1616e Networked Break-in/Break-out Box

[Overview](#)[Description](#)[Getting Started](#)[Dante](#)[FAQ](#)[Front](#)[Rear](#)[Applications](#)[Specifications](#)[Warranty](#)

This page is intentionally left blank.

Cautions and Important Safety Instructions

- minimum distances around the apparatus for sufficient ventilation.
- the ventilation should not be impeded by covering the ventilation openings with items, such as newspapers, table-cloths, curtains, etc..
- no naked flame sources, such as lighted candles, should be placed on the apparatus.
- the use of apparatus in tropical and/or moderate climates.

WARRANTY CONDITIONS

UNiKA products are designed and manufactured in Taiwan to the highest quality standard. However, if something does go wrong with a product, UNiKA Electronic Co., Ltd. will repair or replace such product in accordance with this warranty policy in any country served by an authorized UNiKA distributor. This warranty complements any national or regional law obligations of dealers, partner or national distributors and does not affect your statutory rights as a consumer. This warranty will only apply to products purchased from a legal UNiKA distributor or dealer, partner etc. This warranty will be effective from the serial number and initial date of purchase and will be valid for the warranty periods detailed as distributor’s sales and service document. No claim under this warranty will be valid unless accompanied by proof of purchase of the product to which the warranty claim relates. This warranty is transferable from owner to owner and will apply and remain with the product to which it relates from the initial date of purchase for the specified term in the distributor’s Area, as long as it’s supported with the original proof of purchase.



UNiKA Service and Warranty Form

Model	<input type="checkbox"/> NBB-1616 <input type="checkbox"/> NBB-1616e	Date	
User/Buyer information			
Company		Contact	
Tel		Fax	
Website		eMail	
Distributor/Dealer			
Contact		Remark	
Warranty valid date			
Signature and Stamp			